

OPERATOR'S MANUAL



Model 8756 Single Stage Pump Soft Serve Freezer

Original Operating Instructions

069071-M

11/15/10 (Original Publication)
(Updated 8/14/14)

Complete this page for quick reference when service is required:

Taylor Distributor: _____

Address: _____

Phone: _____

Fax: _____

E-mail: _____

Service: _____

Parts: _____

Date of Installation: _____

Information found on the data label:

Model Number: _____

Serial Number: _____

Electrical Specs: Voltage _____ Cycle _____

Phase _____

Maximum Fuse Size: _____ A

Minimum Wire Ampacity: _____ A

© 2010 Carrier Commercial Refrigeration, Inc.
069071-M

Any unauthorized reproduction, disclosure, or distribution of copies by any person of any portion of this work may be a violation of Copyright Law of the United States of America and other countries, could result in the awarding of Statutory Damages of up to \$250,000 (17 USC 504) for infringement, and may result in further civil and criminal penalties. All rights reserved.



Taylor Company
a division of Carrier Commercial Refrigeration, Inc.
750 N. Blackhawk Blvd.
Rockton, IL 61072

Table of Contents

Section 1	To the Installer	1
	Installer Safety	1
	Site Preparation	1
	Air Cooled Units	1
	Water Connections (Water Cooled Units Only)	2
	Electrical Connections	2
	Beater Rotation	3
	Refrigerant	3
Section 2	To the Operator	4
Section 3	Safety	5
Section 4	Operator Parts Identification	8
	Beater Door Assembly	10
	Air/Mix Pump Assembly	11
	Accessories	12
Section 5	Important: To the Operator	13
	Symbol Definitions	14
	Power Switch	14
	Indicator Lights - MIX LOW and MIX OUT	14
	Reset Button	14
	MIX REF	14
	Standby	14
	Wash	15
	Auto	15
	Pump	15
	Adjustable Draw Handle	15
Section 6	Operating Procedures	16
	Assembly	16
	Air/Mix Pump Assembly	21
	Sanitizing	25
	Priming	28

Closing Procedure	29
Draining Product From the Freezing Cylinder	30
Rinsing	30
Cleaning	31
Disassembly	32
Brush Cleaning	33
Section 7 Important: Operator Checklist	34
During Cleaning and Sanitizing	34
Troubleshooting Bacterial Count	34
Regular Maintenance Checks	34
The Air/Mix Pump	35
Section 8 Troubleshooting Guide	36
Section 9 Parts Replacement Schedule	41
Section 10 Limited Warranty on Equipment	42
Section 11 Limited Warranty on Parts	44
Section 12 Parts List	47
Wiring Diagram	56

Note: Continuing research results in steady improvements; therefore, information in this manual is subject to change without notice.

Note: Only instructions originating from the factory or its authorized translation representative(s) are considered to be the original set of instructions.

© 2010 Carrier Commercial Refrigeration, Inc. (Original Publication)
(Updated August, 2014)
069071-M

Any unauthorized reproduction, disclosure, or distribution of copies by any person of any portion of this work may be a violation of Copyright Law of the United States of America and other countries, could result in the awarding of Statutory Damages of up to \$250,000 (17 USC 504) for infringement, and may result in further civil and criminal penalties. All rights reserved.



Taylor Company
a division of Carrier Commercial Refrigeration, Inc.
750 N. Blackhawk Blvd.
Rockton, IL 61072

Section 1

To the Installer

The following information has been included in the manual as safety and regulatory guidelines. For complete installation instructions, please see the Installation Checklist.

Installer Safety



In all areas of the world, equipment should be installed in accordance with existing local codes. Please contact your local authorities if you have any questions.

Care should be taken to ensure that all basic safety practices are followed during the installation and servicing activities related to the installation and servicing of Taylor equipment.

- Only authorized Taylor service personnel should perform installation and repairs on the equipment.
- Authorized service personnel should consult OSHA Standard 29CFR1910.147 or the applicable code of the local area for the industry standards on lockout/tagout procedures before beginning any installation or repairs.
- Authorized service personnel must ensure that the proper PPE is available and worn when required during installation and service.
- Authorized service personnel must remove all metal jewelry, rings, and watches before working on electrical equipment.



The main power supply(s) to the freezer must be disconnected prior to performing any repairs. Failure to follow this instruction may result in personal injury or death from electrical shock or hazardous moving parts as well as poor performance or damage to the equipment.

Note: All repairs must be performed by an authorized Taylor Service Technician.



This unit has many sharp edges that can cause severe injuries.

Site Preparation

Review the area where the unit will be installed before uncrating the unit. Make sure all possible hazards to the user or equipment have been addressed.

For Indoor Use Only: This unit is designed to operate indoors, under normal ambient temperatures of 70°-75°F (21°-24°C). The freezer has successfully performed in high ambient temperatures of 104° (40°C) at reduced capacities.



This unit must **NOT** be installed in an area where a water jet or hose can be used. **NEVER** use a water jet or hose to rinse or clean the unit. Failure to follow this instruction may result in electrocution.



This unit must be installed on a level surface to avoid the hazard of tipping. Extreme care should be taken when moving this equipment for any reason. Two or more people are required to safely move this unit. Failure to comply may result in personal injury or equipment damage.

Uncrate the unit and inspect it for damage. Report any damage to your Taylor Distributor.

This piece of equipment is made in the USA and has USA sizes of hardware. All metric conversions are approximate and vary in size.

Air Cooled Units

DO NOT obstruct air intake and discharge openings:

Air cooled units require a minimum of 3" (76 mm) of clearance around all sides of the freezer and 12" (305 mm) on top to allow for adequate air flow across the condenser(s). Failure to allow adequate clearance can reduce the refrigeration capacity of the freezer and possibly cause permanent damage to the compressor.

Water Connections (Water Cooled Units Only)

An adequate cold water supply must be provided with a hand shut-off valve. On the underside of the base pan, two 3/8" I.P.S. (for single-head units) or two 1/2" I.P.S. (for double-head units) water connections for inlet and outlet have been provided for easy hook-up. 1/2" inside diameter water lines should be connected to the machine. (Flexible lines are recommended, if local codes permit.) Depending on local water conditions, it may be advisable to install a water strainer to prevent foreign substances from clogging the automatic water valve. There will be only one water "in" and one water "out" connection for both single-head and double-head units. **DO NOT** install a hand shut-off valve on the water "out" line! Water should always flow in this order: first, through the automatic water valve; second, through the condenser; and third, through the outlet fitting to an **open trap drain**.



A back flow prevention device is required on the incoming water connection side. Please refer to the applicable National, State, and local codes for determining the proper configuration.

Electrical Connections

In the United States, this equipment is intended to be installed in accordance with the National Electrical Code (NEC), ANSI/NFPA 70-1987. The purpose of the NEC code is the practical safeguarding of persons and property from hazards arising from the use of electricity. This code contains provisions considered necessary for safety. In all other areas of the world, equipment should be installed in accordance with the existing local codes. Please contact your local authorities.



FOLLOW YOUR LOCAL ELECTRICAL CODES!

Each unit requires one power supply for each data label on the unit. Check the data label(s) on the freezer for branch circuit overcurrent protection or fuse, circuit ampacity, and other electrical specifications. Refer to the wiring diagram provided inside of the electrical box for proper power connections.



CAUTION: THIS EQUIPMENT MUST BE PROPERLY GROUNDED! FAILURE TO DO SO CAN RESULT IN SEVERE PERSONAL INJURY FROM ELECTRICAL SHOCK!



This unit is provided with an equipotential grounding lug that is to be properly attached to the rear of the frame by the authorized installer. The installation location is marked by the equipotential bonding symbol (5021 of IEC 60417-1) on both the removable panel and the equipment's frame.



- Stationary appliances which are not equipped with a power cord and a plug or another device to disconnect the appliance from the power source must have an all-pole disconnecting device with a contact gap of at least 3 mm installed in the external installation.
- Appliances that are permanently connected to fixed wiring and for which leakage currents may exceed 10 mA, particularly when disconnected or not used for long periods or during initial installation, shall have protective devices such as a GFI, to protect against the leakage of current, installed by the authorized personnel to the local codes.

- Supply cords used with this unit shall be oil-resistant, sheathed flexible cable not lighter than ordinary polychloroprene or other equivalent synthetic elastomer-sheathed cord (Code designation 60245 IEC 57) installed with the proper cord anchorage to relieve conductors from strain, including twisting, at the terminals and protect the insulation of the conductors from abrasion.

If the supply cord is damaged, it must be replaced by an authorized Taylor service technician in order to avoid a hazard.

Beater Rotation



Beater rotation must be clockwise as viewed looking into the freezing cylinder.



The following procedures must be performed by an authorized Taylor service technician.

To correct the rotation on a three-phase unit, interchange any two incoming power supply lines at freezer main terminal block only.

To correct rotation on a single-phase unit, change the leads inside the beater motor. (Follow the diagram printed on the motor.)

Electrical connections are made directly to the terminal block provided in the main control box.

Refrigerant



In consideration of our environment, Taylor uses only HFC refrigerants. The HFC refrigerant used in this unit is R404A. This refrigerant is generally considered non-toxic and non-flammable, with an Ozone Depleting Potential (ODP) of zero (0).

However, any gas under pressure is potentially hazardous and must be handled with caution.

NEVER fill any refrigerant cylinder completely with liquid. Filling the cylinder to approximately 80% will allow for normal expansion.



Use only R404A refrigerant that conforms to the AHRI standard 700 specification. The use of any other refrigerant may expose users and operators to unexpected safety hazards.



Refrigerant liquid sprayed onto the skin may cause serious damage to tissue. Keep eyes and skin protected. If refrigerant burns should occur, flush immediately with cold water. If burns are severe, apply ice packs and contact a physician immediately.



Taylor reminds technicians to be cautious of government laws regarding refrigerant recovery, recycling, and reclaiming systems. If you have any questions regarding these laws, please contact the factory Service Department.



WARNING: R404A refrigerant used in conjunction with polyolester oils is extremely moisture absorbent. When opening a refrigeration system, the maximum time the system is open must not exceed 15 minutes. Cap all open tubing to prevent humid air or water from being absorbed by the oil.

Section 2

To the Operator

The unit you have purchased has been carefully engineered and manufactured to give you dependable operation. This unit, when properly operated and cared for, will produce a consistent quality product. Like all mechanical products, it will require cleaning and maintenance. A minimum amount of care and attention is necessary if the operating procedures outlined in this manual are followed closely.

This Operator's Manual should be read before operating or performing any maintenance on the unit.

Your Taylor unit will NOT compensate for and/or correct any errors made during the set-up or filling operations. Thus, the initial assembly, set-up, and priming procedures are of extreme importance. It is strongly recommended that all personnel responsible for the unit's operation, including assembly and disassembly, go through these procedures together in order to be properly trained and to make sure that all understand their role in using and maintaining the unit.

In the event you should require technical assistance, please contact your local authorized Taylor Distributor.

Note: Your Taylor warranty is valid only if the parts are authorized Taylor parts, purchased from the local authorized Taylor Distributor, and only if all required service work is provided by an authorized Taylor service technician. Taylor reserves the right to deny warranty claims on units or parts if non-Taylor approved parts or incorrect refrigerant were installed in the unit, system modifications were performed beyond factory recommendations, or it is determined that the failure was caused by abuse, misuse, neglect, or failure to follow all operating instructions. For full details of your Taylor Warranty, please see the Limited Warranty section in this manual.



If the crossed out wheeled bin symbol is affixed to this unit, it signifies that this unit is compliant with the EU Directives as well as other similar end of life legislation in effect after August 13, 2005. Therefore, it must be collected separately after its use is completed, and cannot be disposed

as unsorted municipal waste. The user is responsible for returning the unit to the appropriate collection facility, as specified by your local code.

For additional information regarding applicable local disposal laws, please contact the municipal waste facility and/or local authorized Taylor distributor.

Compressor Warranty Disclaimer

The refrigeration compressor(s) on this unit are warranted for the term stated in the Limited Warranty section in this manual. However, due to the Montreal Protocol and the U.S. Clean Air Act Amendments of 1990, many new refrigerants are being tested and developed, thus seeking their way into the service industry. Some of these new refrigerants are being advertised as drop-in replacements for numerous applications. It should be noted that in the event of ordinary service to this unit's refrigeration system, **only the refrigerant specified on the affixed data label should be used.** The unauthorized use of alternate refrigerants will void your Taylor compressor warranty. It is the unit owner's responsibility to make this fact known to any technician he employs.

It should also be noted that Taylor does not warrant the refrigerant used in its equipment. For example, if the refrigerant is lost during the course of ordinary service to this unit, Taylor has no obligation to either supply or provide replacement refrigerant either at billable or unbillable terms. Taylor will recommend a suitable replacement if the original refrigerant is banned, obsoleted, or no longer available during the five (5) year Taylor warranty of the compressor.

From time-to-time Taylor may test new refrigerant alternates. Should a new refrigerant alternate prove, through Taylor's testing, that it would be accepted as a drop-in replacement for this unit, then the disclaimer in this "Compressor Warranty Disclaimer" section will not apply to the use of the alternate refrigerant approved by Taylor.

To find out the current status of an alternate refrigerant as it relates to your compressor warranty, call Taylor or your local authorized Taylor distributor. Be prepared to provide the Model/Serial Number of the unit in question.

Note: Continuing research results in steady improvements; therefore, information in this Operator Manual is subject to change without notice.

We, at Taylor Company, are concerned about the safety of the operator at all times when they are coming in contact with the unit and its parts. Taylor makes every effort to design and manufacture built-in safety features to protect both operators and service technicians.

Installing and servicing refrigeration equipment can be hazardous due to system pressure and electrical components. Only trained and qualified service personnel should install, repair, or service refrigeration equipment. When working on refrigeration equipment, observe precautions noted in the literature, tags and labels attached to the unit, and other safety precautions that may apply. Follow all safety code requirements. Wear safety glasses and work gloves.



IMPORTANT - Failure to adhere to the following safety precautions may result in severe personal injury or death. Failure to comply with these warnings may also damage the unit and/or its components. Such damage may result in component replacement and service repair expenses.



DO NOT operate the unit without reading this entire Operator Manual first. Failure to follow all of these operating instructions may result in damage to the unit, poor performance, health hazards, personal injury, or death.



This unit is to be used only by trained personnel. It is not intended for use by children or people with reduced physical, sensory, or mental capabilities, or lack of experience and knowledge. Where limited equipment operation is allowed for public use, such as a self-serve application, supervision or instruction concerning the use of the appliance by a person responsible for their safety is required. Children should be supervised to ensure that they do not play with the appliance.



- All repairs should be performed by an authorized Taylor service technician.
- The main power supplies to the unit must be disconnected prior to performing installation, repairs, or maintenance.
- **DO NOT** operate the unit unless it is properly grounded.
- **DO NOT** operate the unit with larger fuses than specified on the unit's data label.
- Cord Connected Units: Only Taylor authorized service technicians or licensed electricians may install a plug or replacement cord on these units.
- Units that are permanently connected to fixed wiring and for which leakage currents may exceed 10 mA, particularly when disconnected or not used for long periods, or during initial installation, shall have protective devices such as a GFI, to protect against the leakage of current, installed by the authorized personnel to the local codes.
- Stationary units which are not equipped with a power cord and a plug or another device to disconnect the appliance from the power source must have an all-pole disconnecting device with a contact gap of at least 3 mm installed in the external installation.
- Supply cords used with this unit shall be oil-resistant, sheathed flexible cable not lighter than ordinary polychloroprene or other equivalent synthetic elastomer-sheathed cord (Code designation 60245 IEC 57) installed with the proper cord anchorage to relieve conductors from strain, including twisting, at the terminals and protect the insulation of the conductors from abrasion.

If the supply cord is damaged, it must be replaced by an authorized Taylor service technician in order to avoid a hazard.

Failure to follow these instructions may result in electrocution. Contact your local authorized Taylor Distributor for service.



DO NOT use a water jet to clean or rinse the unit. Failure to follow these instructions may result in serious electrical shock.



- **DO NOT** allow untrained personnel to operate this unit.
- **DO NOT** operate the unit unless all service panels and access doors are restrained with screws.
- **DO NOT** remove any internal operating parts (including, but not limited to, freezer door, beater, or scraper blades), unless all control switches are in the OFF position.

Failure to follow these instructions may result in severe personal injury, especially to fingers or hands, from hazardous moving parts.



This unit has many sharp edges that can cause severe injuries.

- **DO NOT** put objects or fingers in the door spout. This may contaminate the product and cause severe personal injury from blade contact.
- **USE EXTREME CAUTION** when removing the beater assembly. The scraper blades are very sharp.



This unit must be placed on a level surface. Extreme care should be taken when moving the unit for any reason. Two or more persons are required to safely move this unit. Failure to comply may result in personal injury or damage to the unit.



Access to the service area of the unit must be restricted to persons having knowledge and practical experience with the unit, in particular as far as safety and hygiene are concerned.



Cleaning and sanitizing schedules are governed by your state or local regulatory agencies and must be followed accordingly. Please refer to the cleaning section of this Operator Manual for the proper procedure to clean this unit.



This unit is designed to maintain product temperature under 41°F (5°C). Any product being added to this unit must be below 41°F (5°C). Failure to follow this instruction may result in health hazards and poor freezer performance.

DO NOT run the unit without product. Failure to follow this instruction can result in damage to the unit.

DO NOT obstruct air intake and discharge openings:

Air cooled units require a minimum of 3" (76 mm) of clearance around **all** sides of the freezer and 12" (305 mm) on top to allow for adequate air flow across the condenser(s). Failure to allow adequate clearance can reduce the refrigeration capacity of the freezer and possibly cause permanent damage to the compressor.

For Indoor Use Only: This unit is designed to operate indoors, under normal ambient temperatures of 70°-75°F (21°-24°C). The unit has successfully performed in high ambient temperatures of up to 104°F (40°C) at reduced capacities.

NOISE LEVEL: Airborne noise emission does not exceed 78 dB(A) when measured at a distance of 1.0 meter from the surface of the unit and at a height of 1.6 meters from the floor.

Section 4

Operator Parts Identification

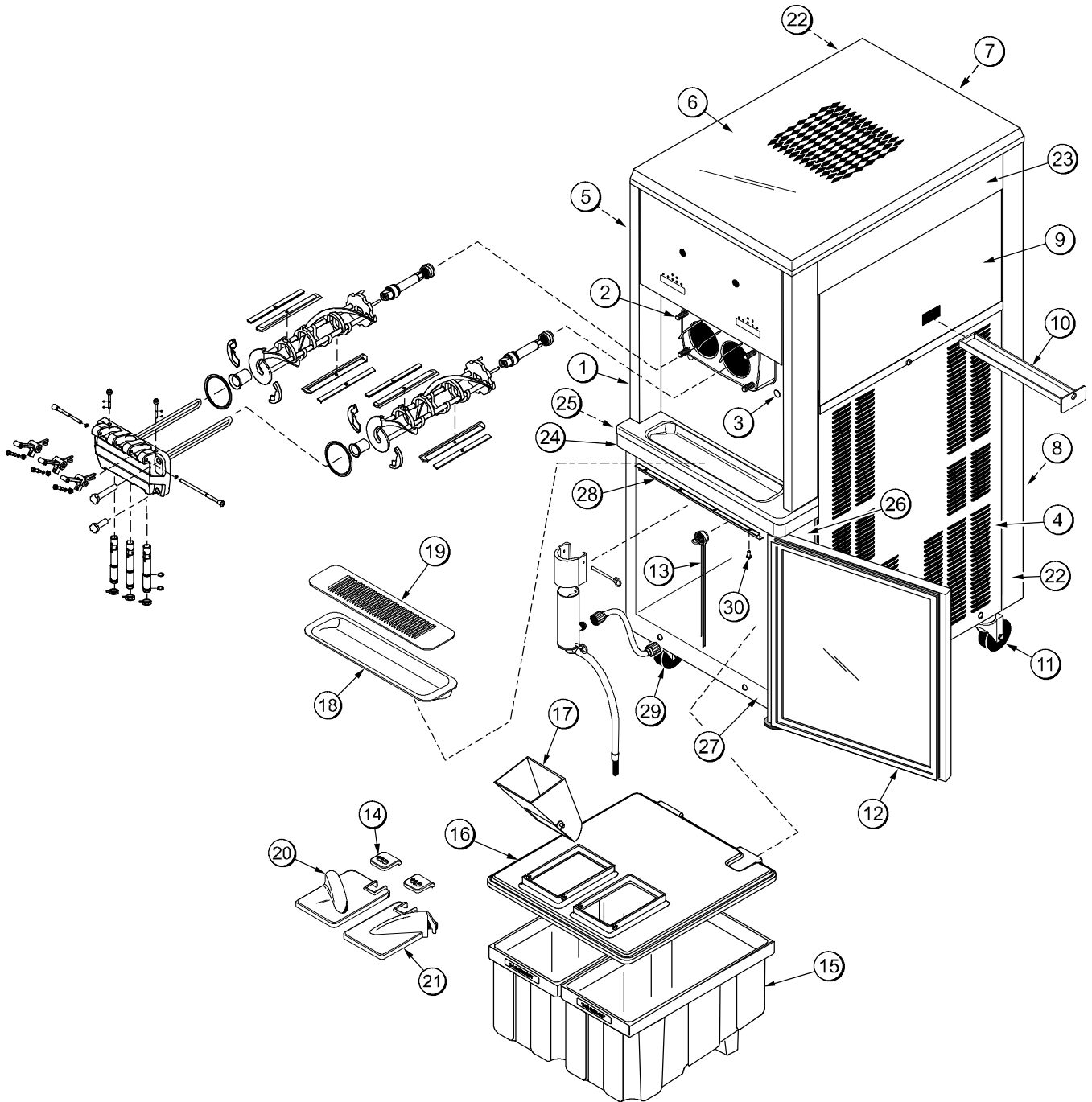

Figure 1

8756 Parts Identification

ITEM	DESCRIPTION	PART NO.
1	PANEL A.-FRONT	X22879
2	STUD-NOSE CONE	068410
3	BOLT-CARRIAGE	012347
4	PANEL A.-LOWER SIDE (R & L)	X23956
5	PANEL-UPPER SIDE LEFT	028599
6	HOOD	048526
7	PANEL-UPPER REAR	022015
8	PANEL-LOWER REAR	023598
9	PANEL-UPPER SIDE RIGHT	028600
10	PAN-DRIP 17-1/4" LONG	027504
11	CASTER-SWIVEL 3/4-10 3" WHL	021279
12	GASKET-CABINET MIX DOOR	024629
13	PROBE A.-MIX (2)	X35981
14	BOOT-MIX COVER	037200
15	TANK A.-MIX W/DECALS	X38755
15a*	TANK (ONLY)	034928

ITEM	DESCRIPTION	PART NO.
16	COVER-MIX TANK	024590
17	FUNNEL-MIX	036637
18	TRAY-DRIP 22-7/8 X 5-1/8	014533
19	SHIELD-SPLASH 23" LONG	022766
20	COVER-LEFT MIX STORAGE	037138
21	COVER-RIGHT MIX STORAGE	037139
22	TRIM-CORNER-LEFT/RIGHT	022013
23	TRIM A.-SIDE LEFT/RIGHT	X22424
24	TRIM A.-SHELF	X24813
25	TRIM-FRONT-LEFT	024824-SP
26	TRIM-FRONT-RIGHT	024825
27	TRIM-BOTTOM CABINET	024826
28	STRIP-TOP TRIM	024827
29	CASTER 3" SWIVEL (FRONT)	030307
30	SCREW-6-32 X 3/8 SLOTTED	002201

*NOT SHOWN

Beater Door Assembly

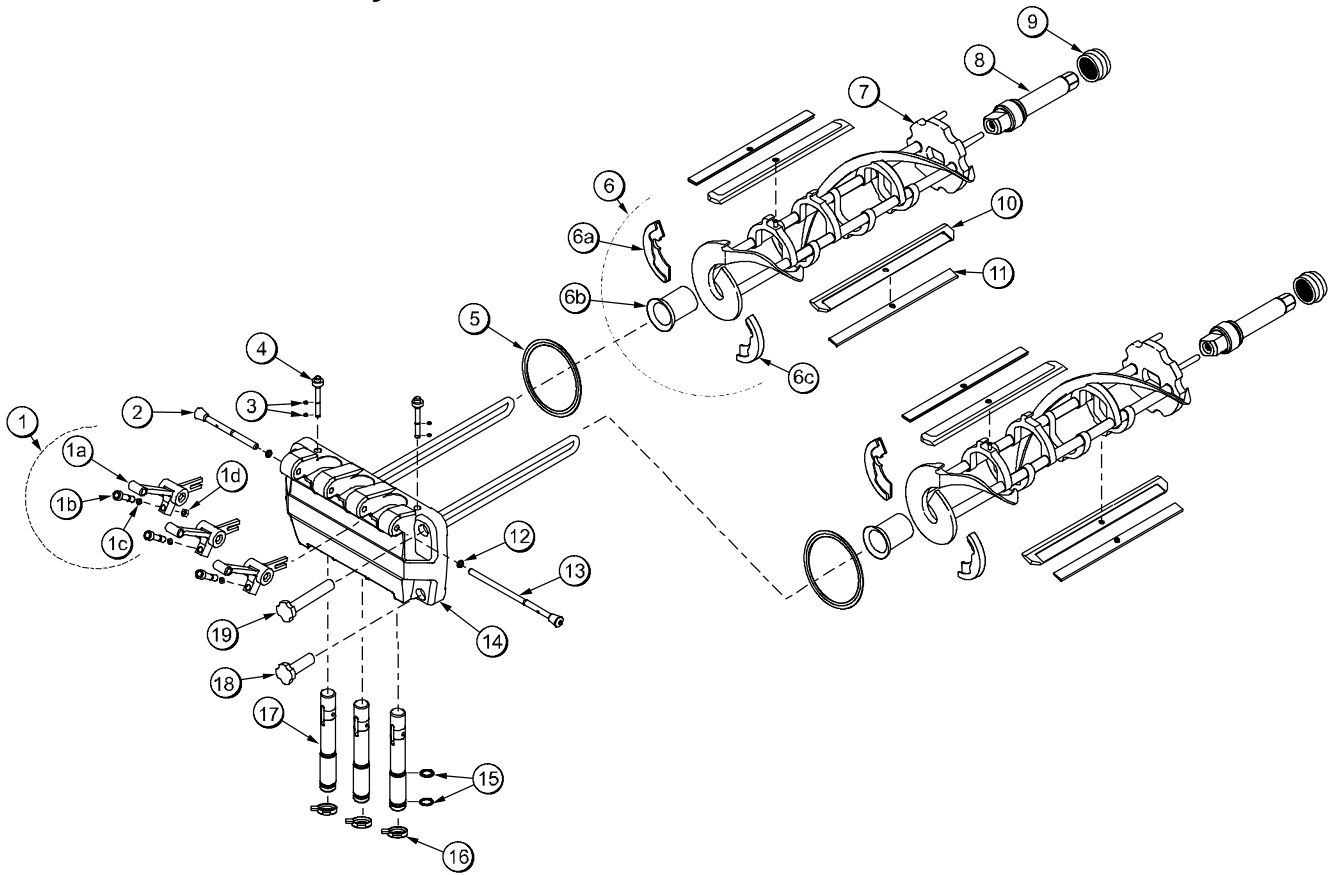
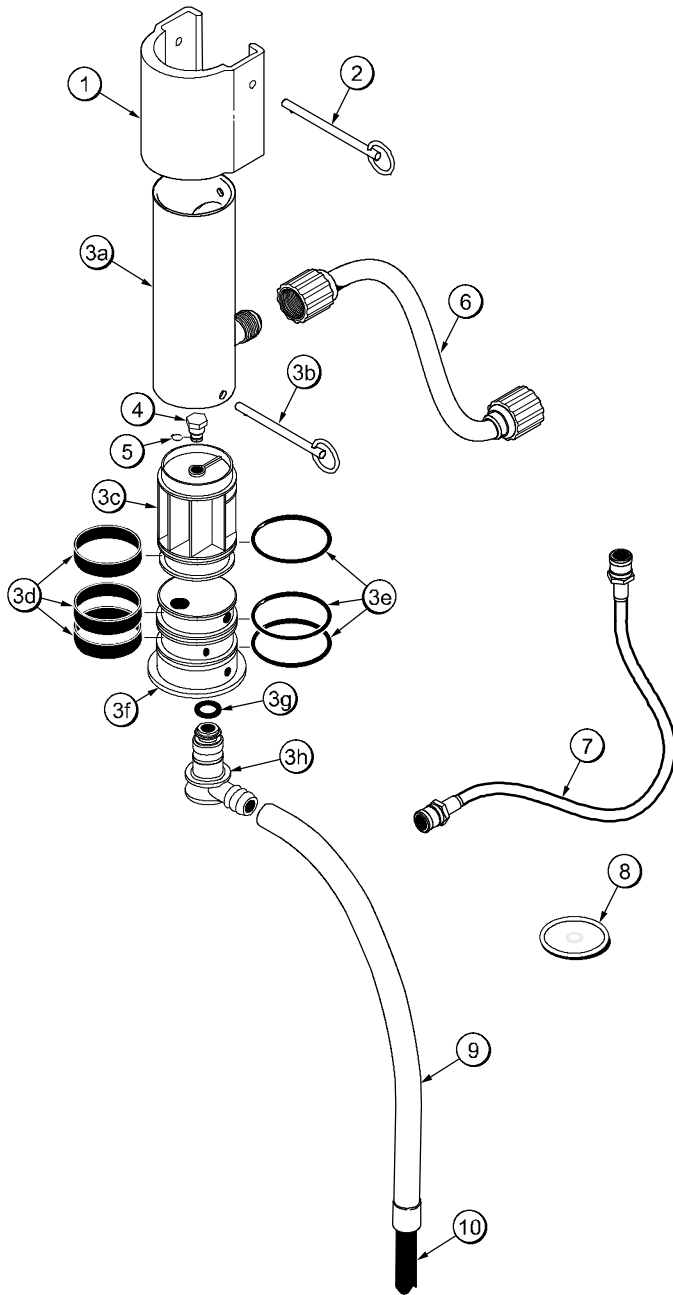

Figure 2

ITEM	DESCRIPTION	PART NO.
1	HANDLE A.-DRAW ADJ	X55096
1a	HANDLE-ADJUSTABLE	028804
1b	SCREW-ADJUSTMENT	055092
1c	O-RING-1/4 OD X .070W 50	015872
1d	NUT-5/16-24 FINISHED HEX	029639-BLK
2	ROD A.-PIVOT-SHORT	X22388
3	O-RING-3/8 OD X .070W	016137
4	PLUG-PRIME	028805
5	GASKET-DOOR HT 4"-DOUBLE	048926
6	KIT A.-BEATER-FRONT SHOES	X50350
6a	SHOE-FRONT HELIX-REAR	050346
6b	BEARING-FRONT-SHOE	050348
6c	SHOE-FRONT HELIX-FRONT	050347

ITEM	DESCRIPTION	PART NO.
7	BEATER A.-3.4QT-1 PIN	X46231
8	SHAFT-BEATER	032564
9	SEAL-DRIVE SHAFT	032560
10	BLADE-SCRAPER-PLASTIC	046235
11	CLIP-SCRAPER-BLADE-7.00-IN	046236
12	O-RING-5/16 OD X .070W	016272
13	ROD A.-PIVOT-LONG	X22387
14	DOOR A.-3 SPOUT	X51532-12
15	O-RING-7/8 OD X .103W	014402
16	CAP-DESIGN-1.010"ID-6 POINT	014218
17	VALVE A.-DRAW	X18303
18	NUT-STUD-SHORT	034383
19	NUT-STUD-LONG	034382

Air/Mix Pump Assembly



ITEM	DESCRIPTION	PART NO.
1	CAP-PUMP	021276-9
2	PIN-RETAINING	021276-8
*3	PUMP A.-SOFT SERVE COMPLETE	X22345
3a	CYLINDER A.-PUMP	022345-1
3b	PIN-RETAINING	021276-8
3c	PISTON	021276-2
3d	RING-CHECK 2" OD x 1/2	020050
3e	O-RING 2-1/8 OD x .139 W	020051
3f	BODY A.-VALVE	X22345-3
3g	O-RING - 13/16 OD x .139 W	021278
3h	ELBOW-INLET 90 DEGREE	022502-4
4	ORIFICE	023425-50
5	O-RING - 3/8 OD x .070 W	016137
6	LINE A.-FLARE	038299
7	LINE A.-PUMP PRESSUSRE	X27139
8	DIAPHRAGM-PRESSURE SWITCH	020249
9	TUBE-VINYL 5/8 ID X 1/8 WALL	020945-18
10	COUNTERWEIGHT-SUCTION TUBE	020452

*INCLUDES ITEMS 3a-3h

Figure 3

Accessories

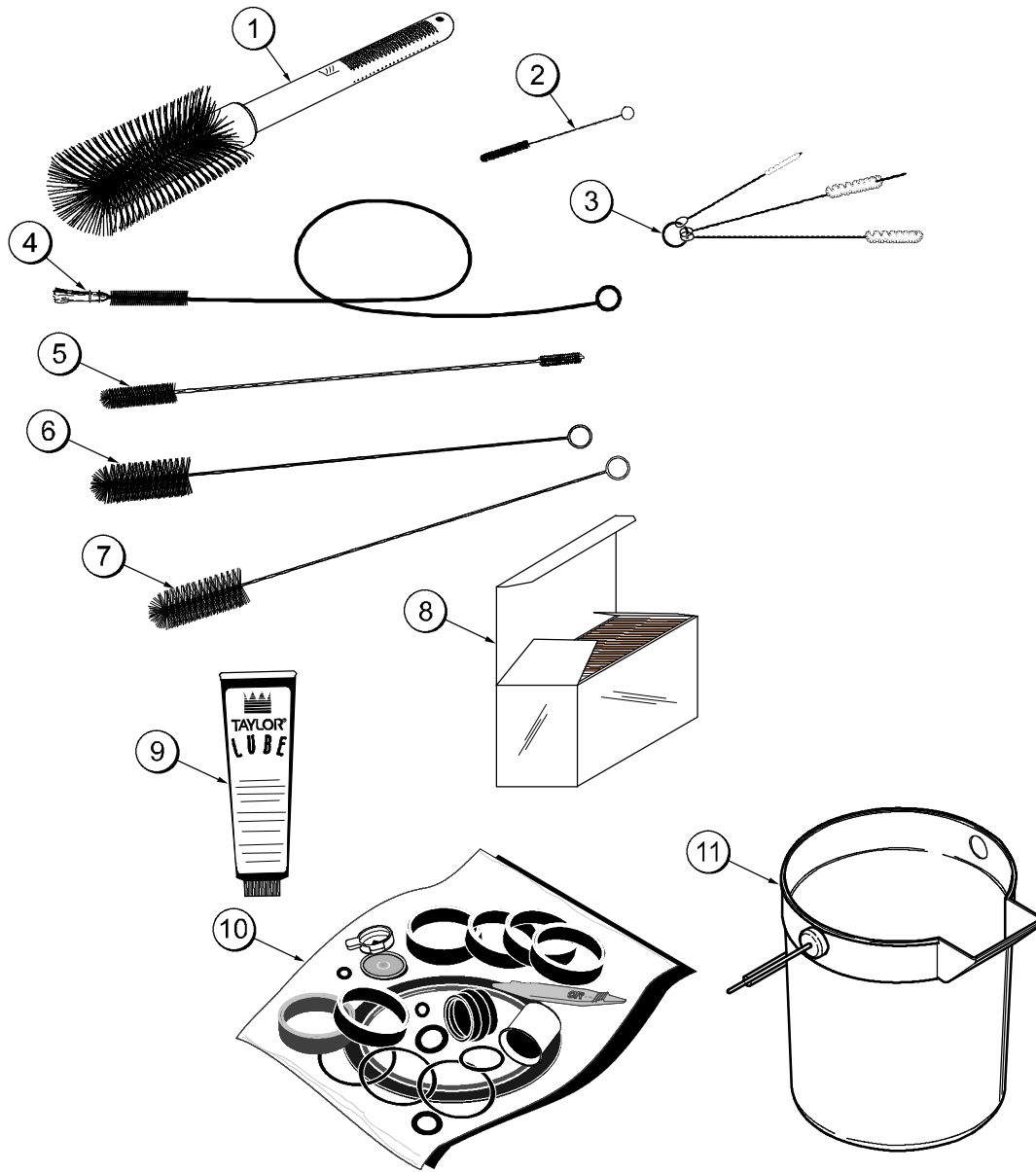

Figure 4

ITEM	DESCRIPTION	PART NO.
1	BRUSH-MIX PUMP BODY	023316
2	BRUSH-PRESSURE SWITCH	027647
3	BRUSH SET-LVB	050103
4	BRUSH-FEED TUBE	021101
5	BRUSH-DOUBLE ENDED	013072
6	BRUSH-REAR BEARING	013071

ITEM	DESCRIPTION	PART NO.
7	BRUSH-DRAW VALVE	013073
*8	SANITIZER-STERA SHEEN GREEN	SEE NOTE
9	LUBRICANT-TAYLOR 4 OZ.	047518
10	KIT A.-TUNE UP	X49463-2
11	PAIL-10 QT.	013163

*Note: A sample container of sanitizer is sent with the unit. For reorders, order Stera Sheen part no. 055492 (100 packs) or Kay-5 part no. 041082 (125 packs).

Section 5

Important: To the Operator

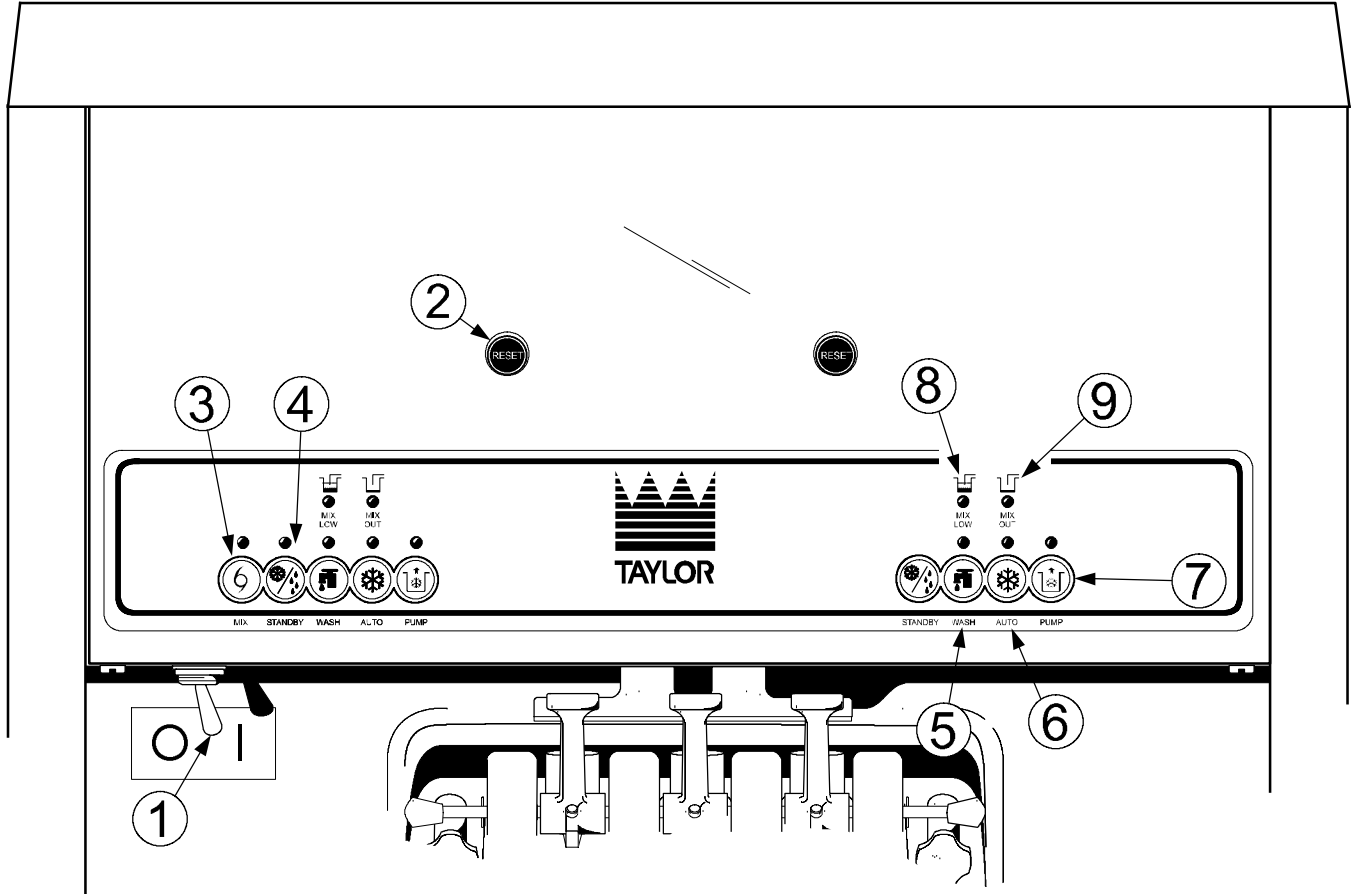

Figure 5

ITEM	DESCRIPTION
1	POWER SWITCH (TOGGLE)
2	RESET SWITCH
3	MIX REFRIGERATION CONTROL
4	STANDBY KEY
5	WASH KEY

ITEM	DESCRIPTION
6	AUTO KEY
7	PUMP KEY
8	MIX LOW INDICATOR
9	MIX OUT INDICATOR

Symbol Definitions

To better communicate in the International arena, the words on many of our operator switches and buttons have symbols to indicate their functions. Your Taylor equipment is designed with these International symbols.



Power Switch

When placed in the ON position, the power switch allows SOFTECH control panel operation.

Indicator Lights - MIX LOW and MIX OUT

When the MIX LOW light begins to flash, the mix tank has a low supply of mix and should be refilled as soon as possible. When the MIX OUT light begins to flash, it indicates the mix tank has been almost completely exhausted and has an insufficient supply of mix to operate the freezer. At this time, the STANDBY and AUTO modes are locked out and the freezer shuts down. To initiate the refrigeration system, add mix to the tank and press the AUTO key. The freezer will automatically begin operation.

Reset Button

The reset button is located in the decorative plate above the SOFTECH controls. The reset protects the beater motor from an overload condition. Should an overload occur, the reset mechanism will trip. To properly reset the freezer, press the AUTO key to cancel the cycle. Turn the power switch to the OFF position. Press the reset button firmly. Turn the power switch to the ON position. Press the WASH key and observe the freezer's performance. The beater motor should be turning the drive shaft in a clockwise (from operator end) direction without binding.

If it is turning properly, press the WASH key to cancel the cycle. Press the AUTO key on both sides to resume normal operation. If the freezer shuts down again, contact a service technician.

MIX REF

When the MIX REF key is pressed, the light comes on, indicating the mix cabinet refrigeration system is operating. There are two touch-tone panels, one for each freezing cylinder. The mix refrigeration system is controlled by the MIX REF key found on the left panel. By pressing the AUTO key on either side of the freezer, the MIX REF function is automatically turned on. The MIX REF function cannot be cancelled unless the AUTO or STANDBY mode is cancelled first.

Standby

During long "No Sale" periods it becomes necessary to warm the product in the freezing cylinder to approximately 35° to 40°F (1.7° to 4.4°C) to prevent overbeating and product breakdown.

When the STANDBY key is pressed, the light comes on, indicating the CTR (Cylinder Temperature Retention System) has been activated. In the STANDBY mode, the WASH, PUMP, and AUTO functions are automatically cancelled. The MIX REF function is automatically locked in to maintain the mix in the cabinet.

To resume normal operation, press the AUTO key. When the unit cycles off, the product in the freezing cylinder will be at serving viscosity.

Wash

When the WASH key is pressed, the light comes on, indicating beater motor operation. The STANDBY or AUTO modes must be cancelled first to activate the WASH mode.

Auto

When the AUTO key is pressed, the light comes on, indicating the main refrigeration system has been activated. In the AUTO mode, the WASH or STANDBY functions are automatically cancelled. The MIX REF function is automatically locked in to maintain the mix in the cabinet and the PUMP function is locked in to allow air/mix pump operation as required.

Pump

When the PUMP key is pressed, the light comes on indicating the air/mix pump will operate as required.

Note: An indicating light and an audible tone will sound whenever a mode of operation has been pressed. To cancel any function, press the key again and the light and mode of operation will shut off.

Adjustable Draw Handle

This unit features an adjustable draw handle to provide the best portion control, giving a better, consistent quality to your product and controlling costs. The draw handle should be adjusted to provide a flow rate of 5 to 7-1/2 oz. of product by weight per 10 seconds. To increase the flow rate, turn the screw counterclockwise. To decrease the flow rate, turn the screw clockwise.

In addition, for purposes of sanitizing and rinsing, the flow rate can be increased by removing the pivot pin and placing the restrictive bar on the **top**.

When drawing product, **always** have the restrictive bar on the **bottom**.

IMPORTANT! When dispensing product, pull only one draw handle at a time.

Section 6

Operating Procedures

The Model 8756 has two freezing cylinders. The size of each freezing cylinder is 3.4 quarts (3.2 liters). Mix is stored in the lower front refrigerated compartment and is pumped up to the freezing cylinder by an air/mix pump.

Duplicate the following procedures, where they apply, for the second freezing cylinder.

We begin our instructions at the point where we enter the store in the morning and find the parts laid out to air dry from the previous night's brush cleaning.

If you are disassembling the machine for the first time, or need information to get to this starting point in our instructions, turn to page 32, "Disassembly" and start there.

Assembly



MAKE SURE THE POWER SWITCH IS IN THE "OFF" POSITION. Failure to follow this instruction may result in electrocution or injury to fingers or hands from hazardous moving parts.

Step 1

Lubricate the groove and shaft portion that comes in contact with the bearing on the beater drive shaft. Slide the seal over the shaft and groove until it snaps into place. **DO NOT lubricate the hex end** of the drive shaft. Fill the inside portion of the seal with 1/4" more lubricant and evenly lubricate the end of the seal that fits onto the rear shell bearing.

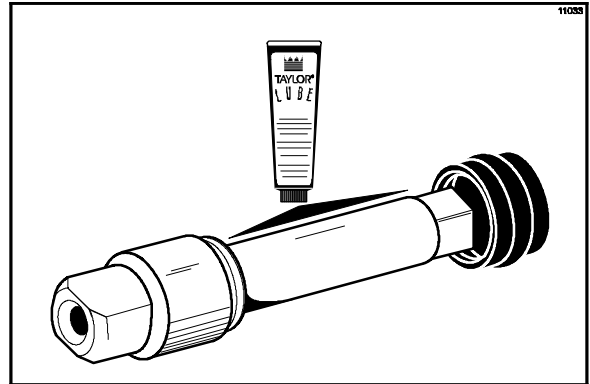

Figure 6

Note: For ease of cleaning, the seal may be turned inside out. Be sure to position the seal correctly during assembly.

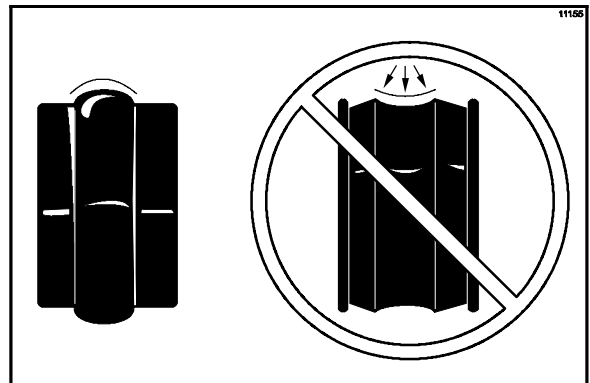

Figure 7

Step 2

Install the drive shaft through the rear shell bearing in the freezing cylinder and engage the hex end firmly into the gear box coupling. Be sure the drive shaft fits into the drive coupling without binding.

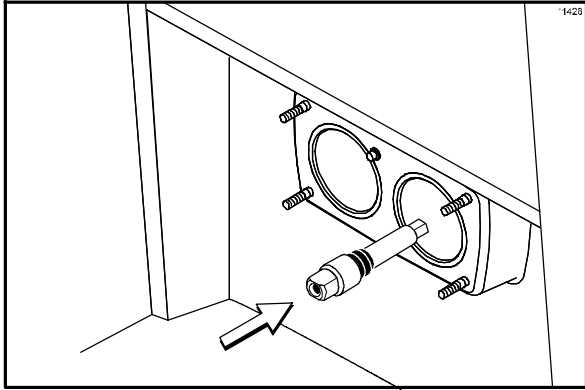

Figure 8

Step 3

Check the scraper blades for any nicks or signs of wear. If any nicks are present, replace both blades.

If the blades are in good condition, install the scraper blade clips on the scraper blades. Place the rear scraper blade over the rear holding pin on the beater.

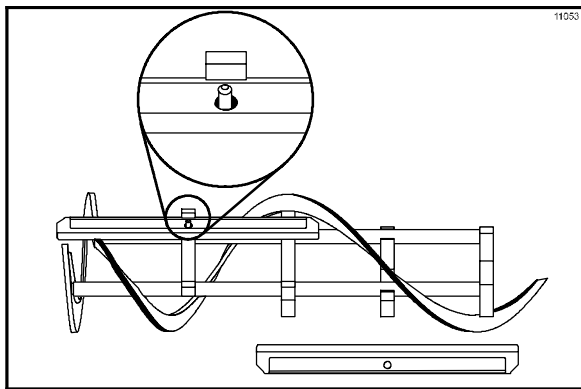

Figure 9

Note: The hole on the scraper blade must fit securely over the pin to prevent costly damage.

Step 4

Holding the rear blade on the beater, slide it into the freezing cylinder half way. Install the front scraper blade over the front holding pin.

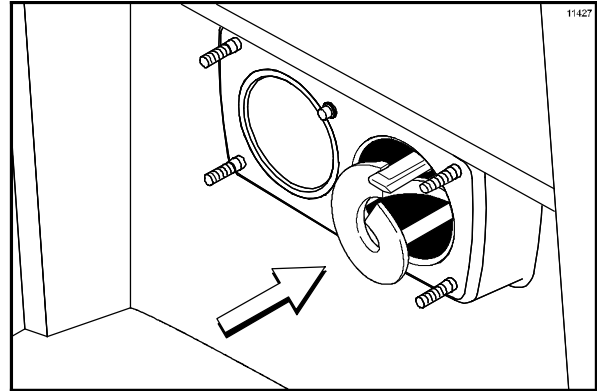

Figure 10

Step 5

Install the beater shoes. Slide the beater assembly the rest of the way into the freezing cylinder.

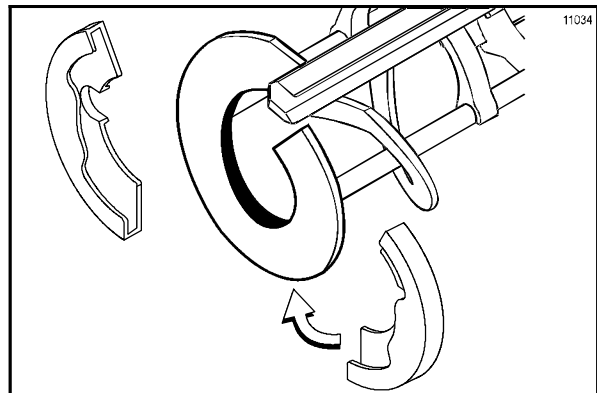

Figure 11

Make sure the beater assembly is in position over the drive shaft. Turn the beater slightly to be certain that the beater is properly seated. When in position, the beater **will not** protrude beyond the front of the freezing cylinder.

Repeat these steps for the other side of the freezer.

Step 6

Place the large rubber gaskets in the grooves on the back side of the freezer door.

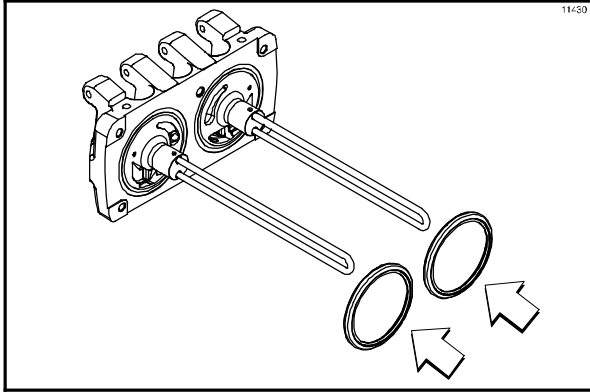

Figure 12

Step 7

Slide the white plastic front bearings over the baffle rods. Make certain that the flanged end of the bearing is resting against the freezer door. **DO NOT lubricate the gaskets or the front bearings.**

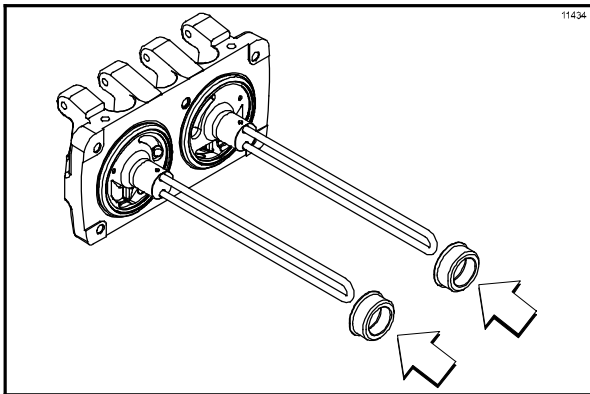

Figure 13

Step 8

Slide the o-rings into the grooves on the prime plugs. Apply an even coat of lubricant to the o-rings and the shafts.

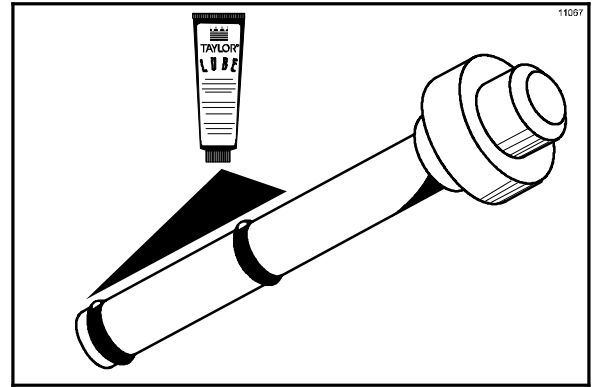

Figure 14

Step 9

Insert the prime plugs into the holes at the top of the freezer door and push down.

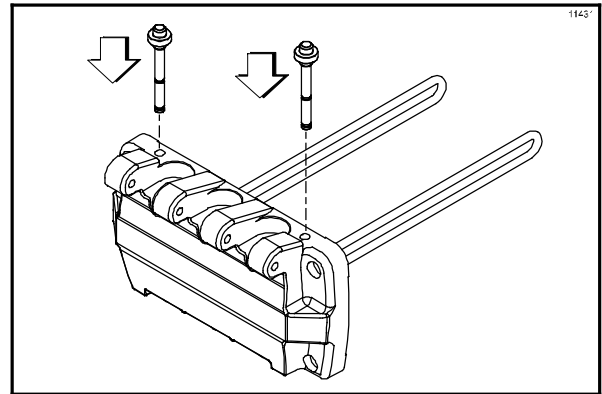

Figure 15

Step 10

Insert the baffle rods through the beaters in the freezing cylinders.

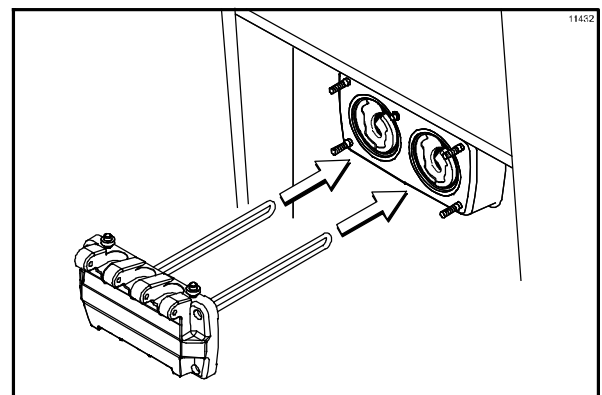

Figure 16

Step 11

With the door seated on the freezer studs, install the short handscrews on the bottom and the long handscrews on the top. Tighten the handscrews equally in a criss-cross pattern until the door is snug.

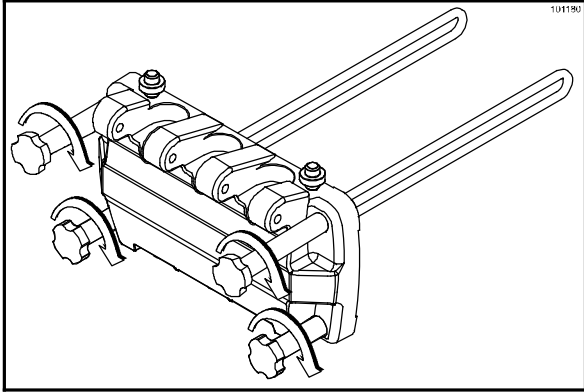

Figure 17

Step 12

Slide the two o-rings into the grooves on the draw valves. Lubricate the o-rings.

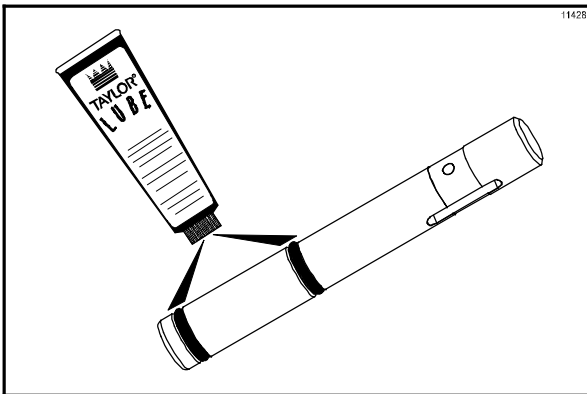

Figure 18

Step 13

Lubricate the inside of the freezer door spouts, top and bottom. Insert the draw valves from the **bottom** of the door until the slot in the draw valves comes into view.

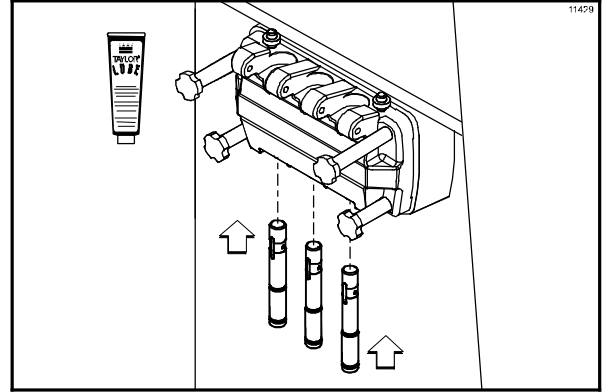

Figure 19

Step 14

Slide the o-rings into the grooves on the pivot pins. Lubricate the o-rings.

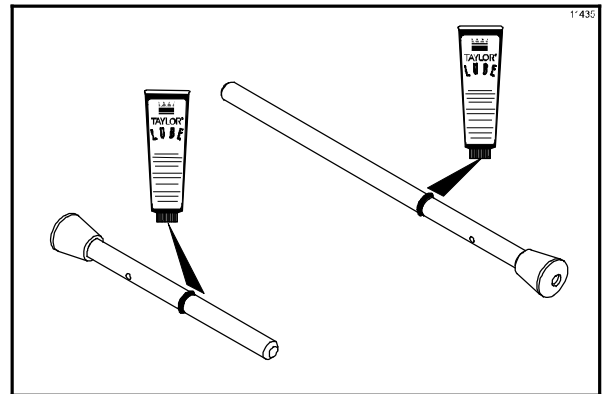

Figure 20

Step 15

Slide the fork of each draw handle into the slot of the draw valves, starting from the right. Slide the long pivot pin through the right and middle draw handles. Secure the left draw handle with the short pivot pin.

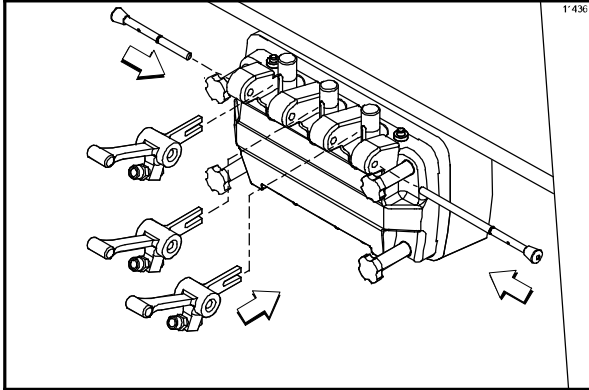

Figure 21

Note: This unit features adjustable draw handles to provide the best portion control, giving a better consistency quality to your product and controlling costs. The draw handles can be adjusted for different flow rates. See page 15 for more information on adjusting these handles.

Step 16

Snap the design caps over the bottom of each door spout.

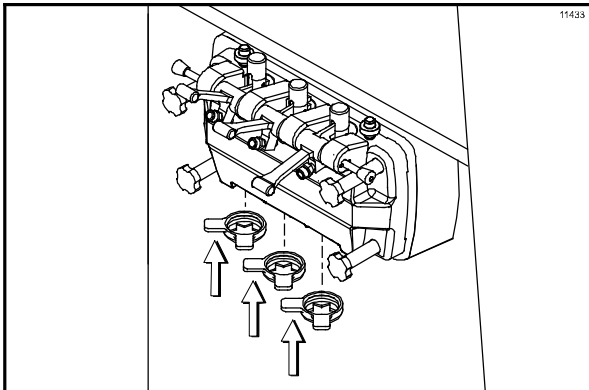

Figure 22

Step 17

Slide the rear drip pan into the hole in the side panel.

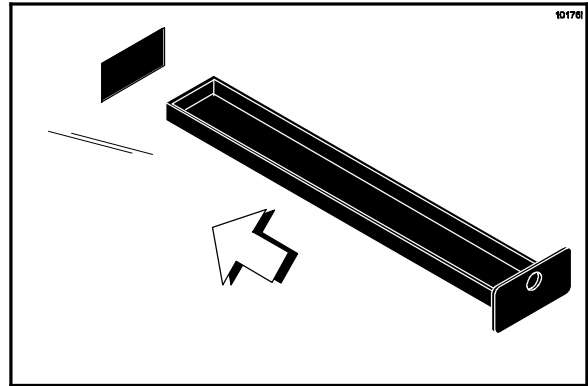

Figure 23

Step 18

Install the front drip tray and the splash shield beneath the door spouts.

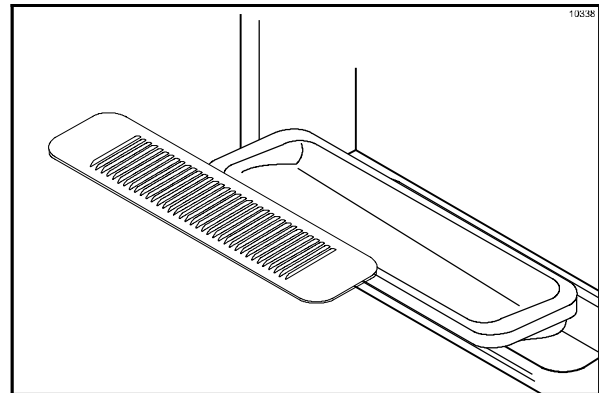

Figure 24

Air/Mix Pump Assembly

This Model 8756 uses a single-stage pump. The purpose of the pump is to transfer specific amounts of air and mix to the freezing cylinder.

Step 1

Assemble the piston by sliding the check band and the o-ring into the grooves on the piston. **Do not lubricate** the check band or o-ring.

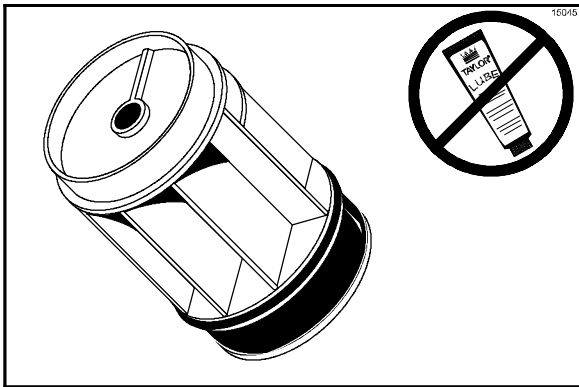

Figure 25

Note: A concave shaped check band indicates an incorrect assembly. Turn the check band inside out to correctly expose the flat surface.

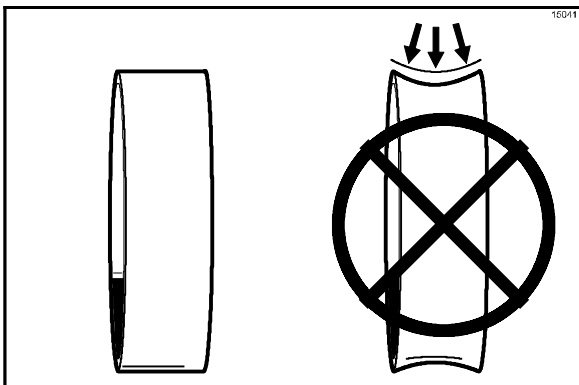

Figure 26

Step 2

Slide the small o-ring into the groove in the air orifice. **DO NOT lubricate** this o-ring.

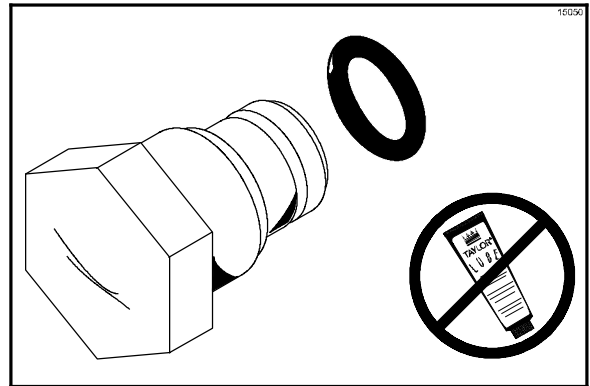

Figure 27

Step 3

Check the small hole in the air orifice to insure that it is not clogged. Place the air orifice into the top of the piston.

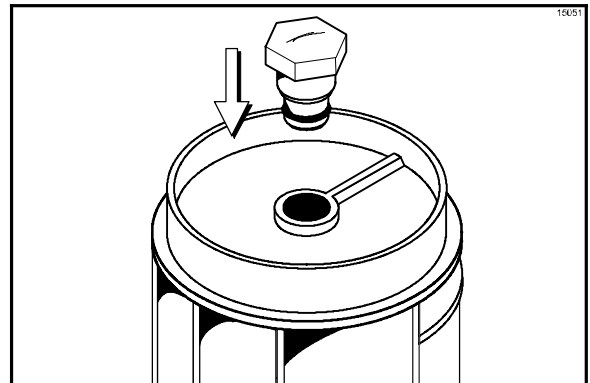

Figure 28

Step 4

Lightly lubricate the inside of the pump body, top and bottom.

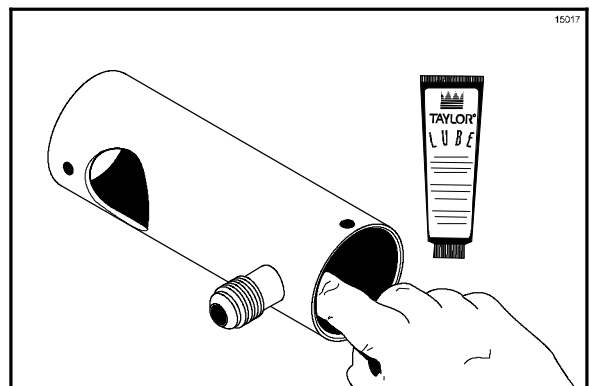

Figure 29

Step 5

Insert the piston, air orifice end first, into the pump body and push upward.

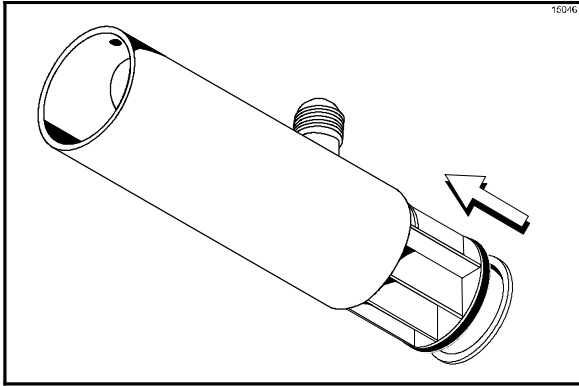

Figure 30

Note: The drive hole in the piston must be visible through the hole in the pump body.

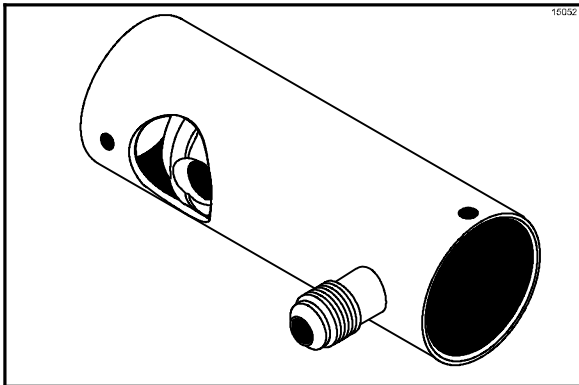

Figure 31

Step 6

Slide the two check bands and the two o-rings into the grooves on the liquid valve body. **Do not lubricate** the check bands or o-rings.

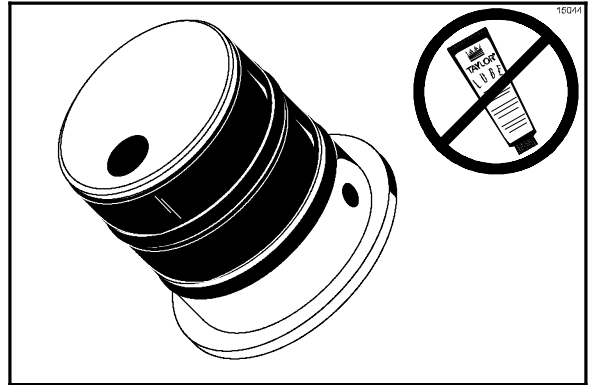

Figure 32

Step 7

Insert the liquid valve body by aligning the steel button at the base of the liquid valve body with the cut-out groove at the bottom of the pump body.

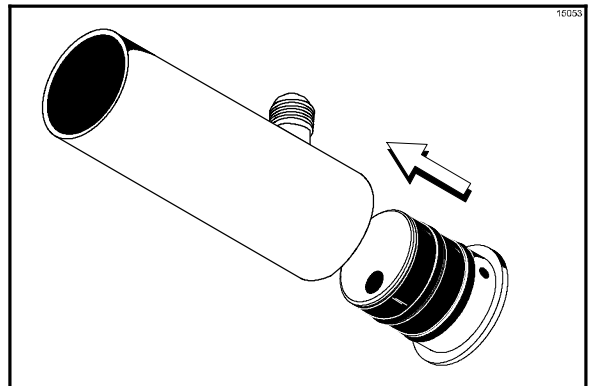

Figure 33

Step 8

Slide the o-ring into the groove on the mix inlet fitting and lubricate the o-ring.

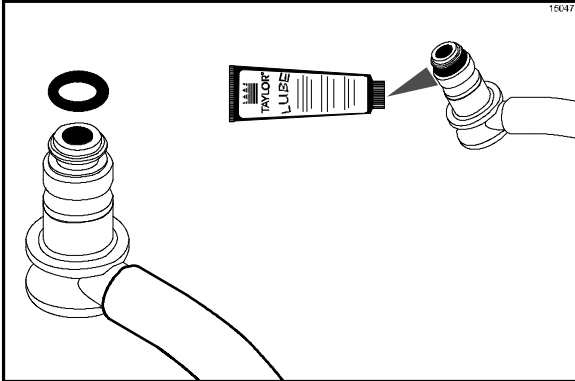

Figure 34

Step 9

Insert the mix inlet fitting into the hole in the base of the liquid valve body.

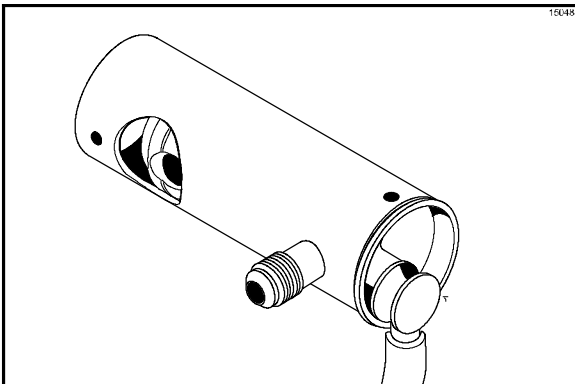

Figure 35

Step 10

Secure the pump parts in position by sliding the keeper pin through the holes located at the bottom of the pump body.

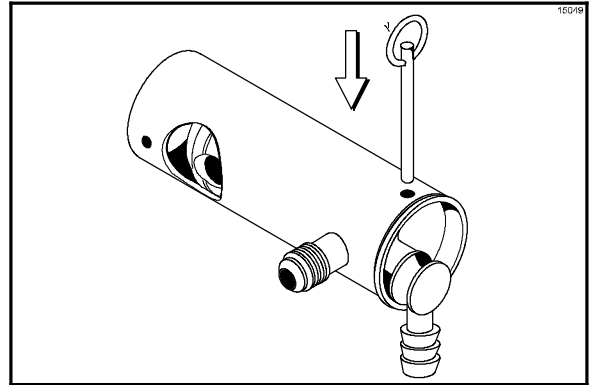

Figure 36

Step 11

Assemble the flare line and suction line. Attach the suction line to the barbed end of the mix inlet fitting and allow the weighted end to hang freely.

Attach one end of the flare line to the threaded fitting on the lower side of the pump body. Allow the other end to hang freely.

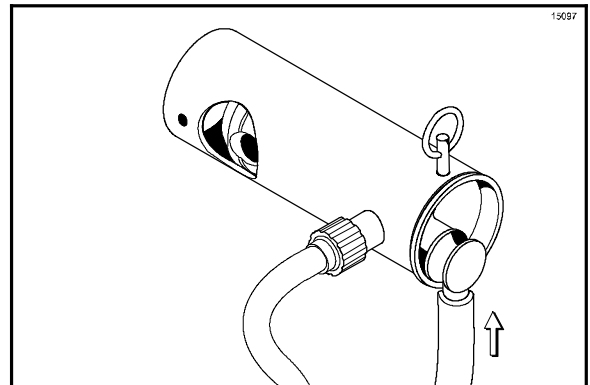

Figure 37

Step 12

To secure the air/mix pump, place the pump collar over the pump body. (The cross holes of the pump collar will be on top.)

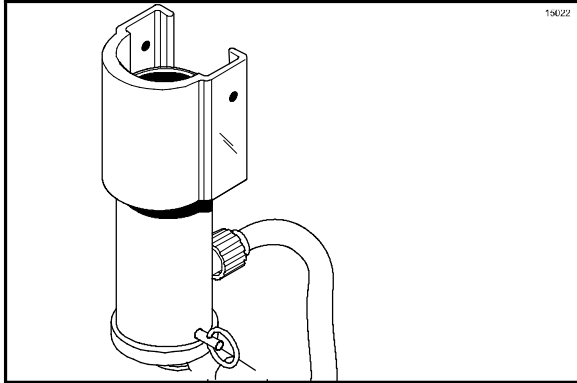

Figure 38

Align the drive hole in the piston to the ball crank of the motor reducer. At the same time, align the locating pin on the face plate.

Slide the pump collar upward into the grooves on the side of the face plate and secure the air/mix pump in place by slipping the keeper pin through the cross holes of the pump collar.

Note: Alignment of the air/mix pump is extremely important. Severe and costly damage may occur if it is not properly aligned.

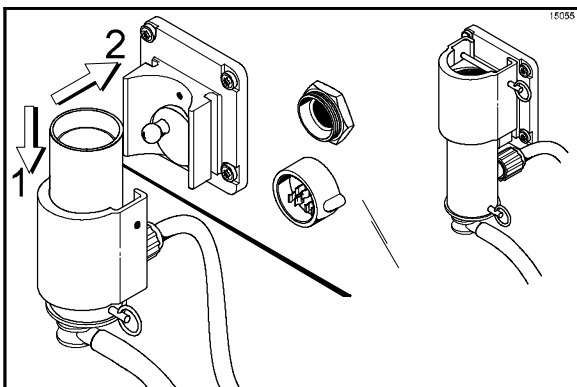

Figure 39

Step 13

Lubricate both sides of the pressure switch diaphragm.

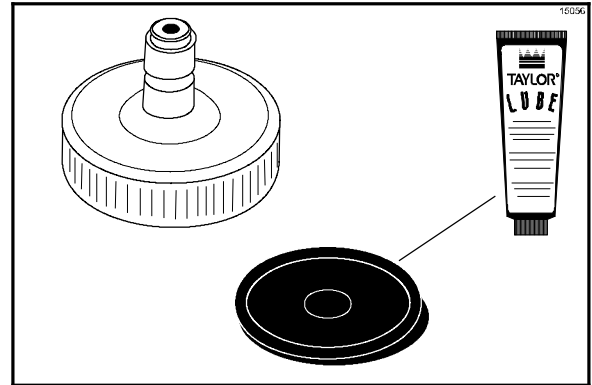

Figure 40

Step 14

Place the diaphragm into its groove in the pressure switch cap.

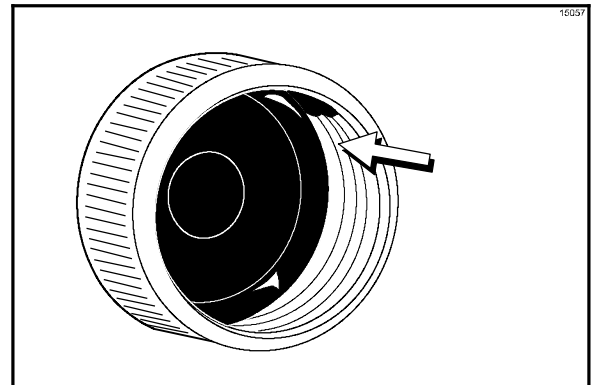

Figure 41

Step 15

Screw the cap securely onto the housing.

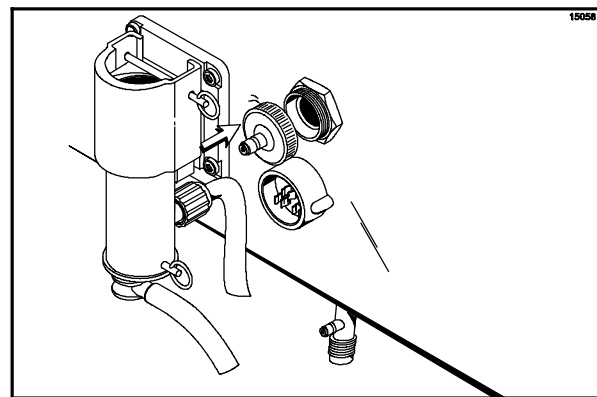

Figure 42

Repeat these steps for the other side of the freezer.

Sanitizing

Step 1

Prepare a pail of approved 100 PPM sanitizing solution (examples: 2-1/2 gal. [9.5 liters] of Kay-5® or 2 gal. [7.6 liters] of Stera-Sheen®). USE WARM WATER AND FOLLOW THE MANUFACTURER'S SPECIFICATIONS.

Step 2

Place the pail of sanitizing solution inside the mix cabinet.

Step 3

Brush clean the mix inlet tube with the long brush and the sanitizing solution.

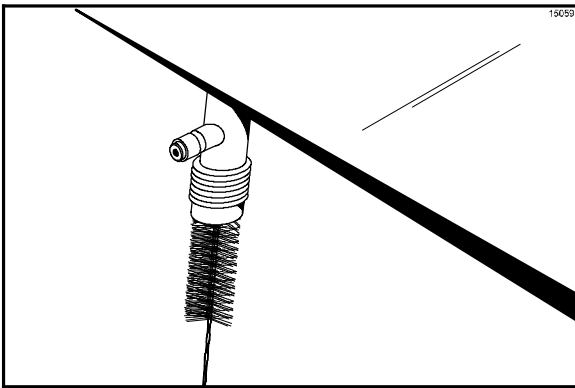

Figure 43

Step 4

Connect the free end of the flare line to the threaded fitting on the mix inlet tube.

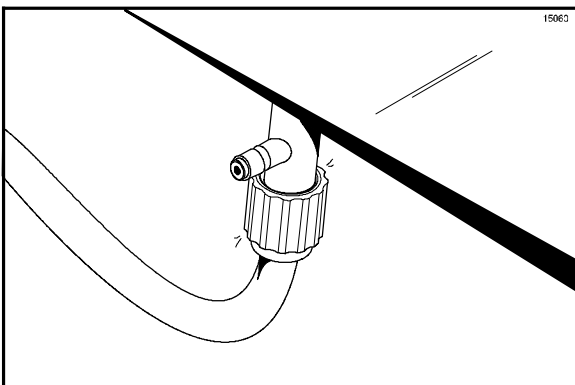

Figure 44

Step 5

Attach the quick disconnect fitting of the pressure line to the other fitting on the mix inlet tube, just above the flare line. Allow the other end to hang free.

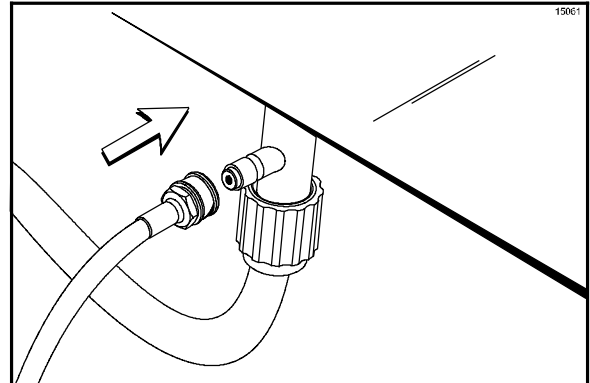

Figure 45

Step 6

Insert the free end of the suction line and the pressure line into the pail of sanitizing solution.

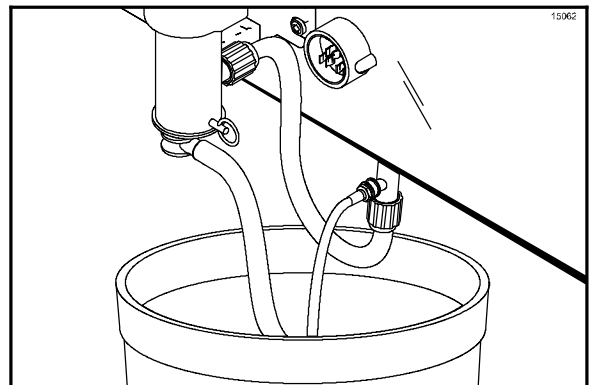

Figure 46

Step 7

Place the power switch in the ON position.

Step 8

Press the PUMP key. A light will illuminate, indicating that the air/mix pump is operating. This action will cause the sanitizing solution to be pumped through the air/mix pump and out through the pressure line. After approximately 15 seconds, press the PUMP key. The light will extinguish and the pump will stop operation.

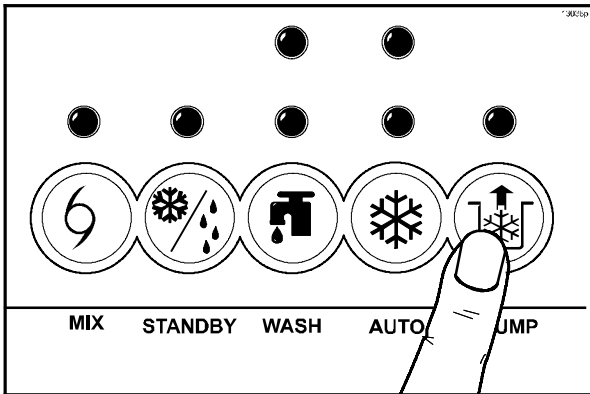

Figure 47

Step 9

Drain the pressure line. Connect the free end of the pressure line to the pressure switch.

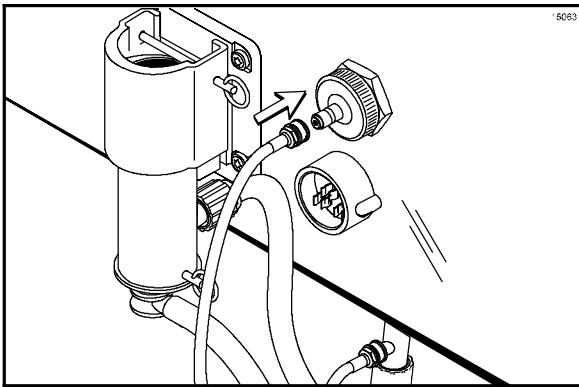

Figure 48

Step 10

Place an empty pail beneath the door spout. Raise the prime plug.

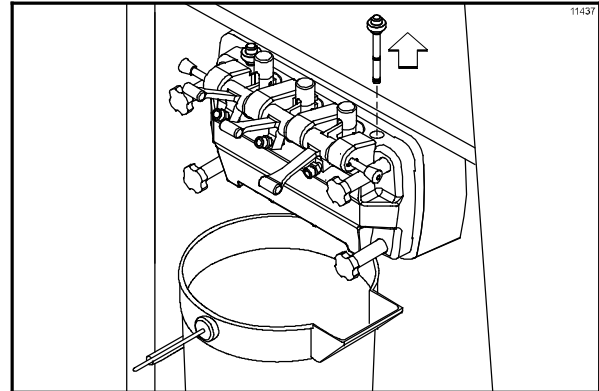

Figure 49

Step 11

Press the WASH and PUMP keys. The indicator lights will illuminate, indicating pump and beater motor operation.

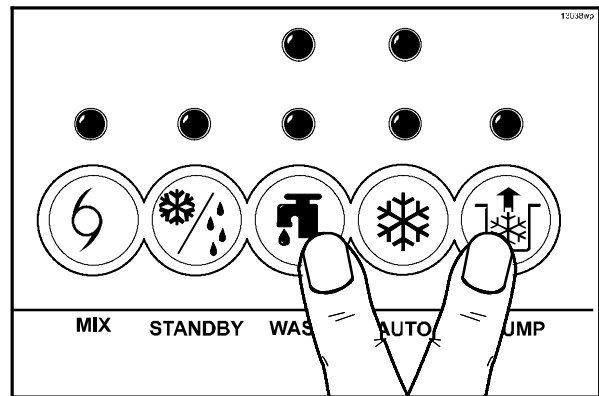

Figure 50

Step 12

When a **steady** stream of sanitizing solution is flowing from the prime plug hole in the bottom of the freezer door, press the PUMP key. This will de-activate pump operation. Push down the prime plug and allow the beater to agitate for 5 minutes.

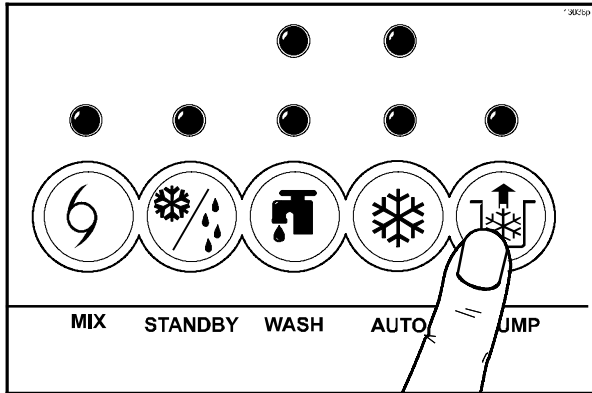

Figure 51

Step 13

After 5 minutes, open the prime plug. Press the PUMP key. Open the draw valve and draw off the remaining sanitizer. Momentarily open the center draw handle to sanitize the center door spout.

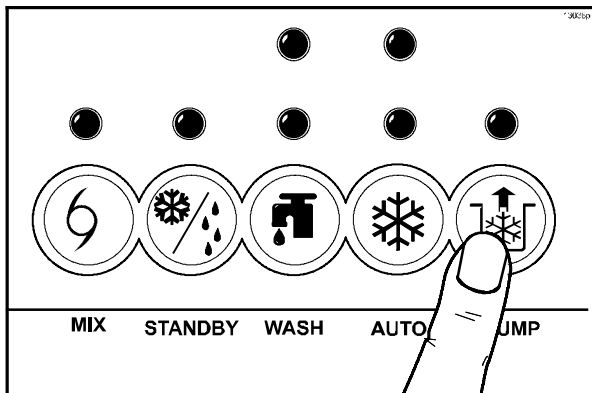

Figure 52

Step 14

When the sanitizer stops flowing from the door spout, close the draw valve. Press the WASH and PUMP keys to stop operation.

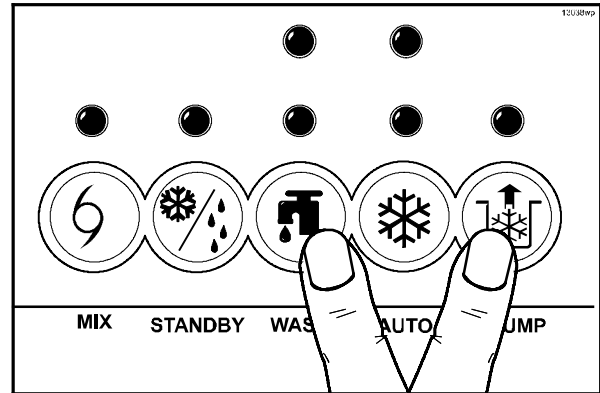

Figure 53

Step 15

Disconnect the pressure line from the pressure switch. Drain the sanitizer. Reconnect the pressure line to the pressure switch.

Repeat these steps for the second freezing cylinder.

Step 16

Prepare a sink with an approved sanitizing solution (examples: Stera Sheen® or Kay-5®). **USE WARM WATER AND FOLLOW THE MANUFACTURER'S SPECIFICATIONS.**

Step 17

Take the following parts to the sink and sanitize: mix tanks, mix tank covers, mix probes, mix storage covers, and funnels.

Priming

Step 1

Place the mix tank and the cover in the mix cabinet.

Step 2

Insert the prongs of the mix probe inside the mix tank. Connect the mix probe in the socket receptacle.

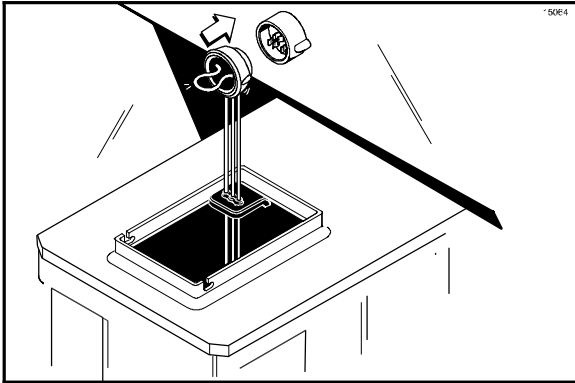

Figure 54

Step 3

Place the free end of the suction line into the mix tank.

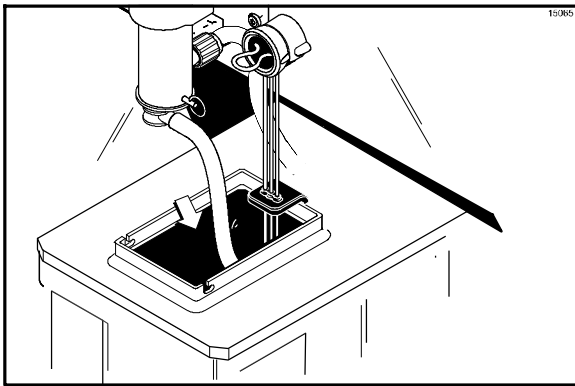

Figure 55

Step 4

Install the funnel. Fill the mix tank with fresh mix.

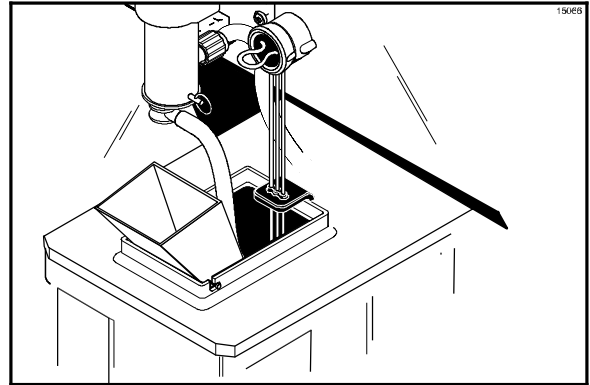

Figure 56

Step 5

Remove the funnel and install the mix storage cover. Close the mix cabinet door.

Step 6

Place an empty pail beneath the door spout and open the draw valve. With the prime plug still in the UP position, press the PUMP key. This will allow the mix to be pumped through the freezing cylinder and force out any remaining sanitizer. When full strength mix is flowing from the door spout, close the draw valve.

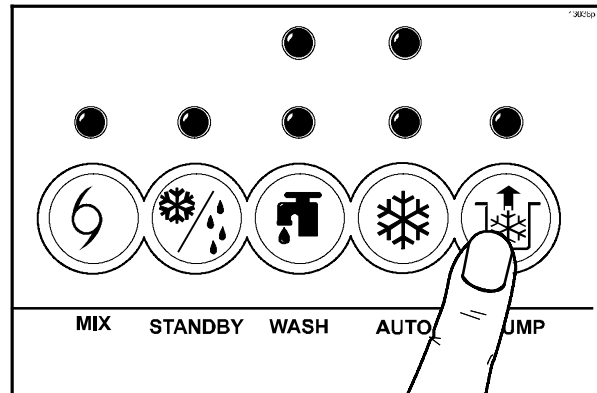

Figure 57

Step 7

When a steady stream of mix is flowing from the prime plug hole in the bottom of the freezer door, press the PUMP key to stop operation.

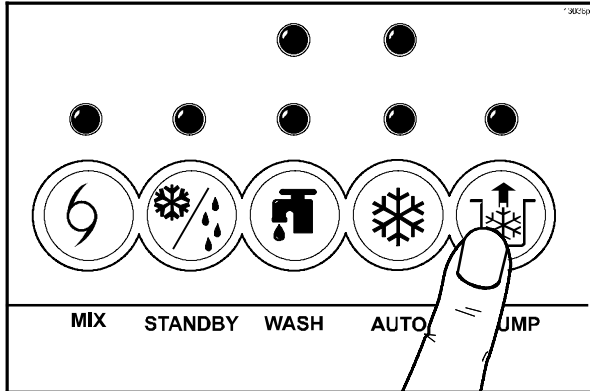

Figure 58

Step 8

Once the stream of mix stops flowing from the prime plug hole, push down the prime plug. Rinse the prime plug hole area with water. Remove the pail and discard the mix and sanitizer.

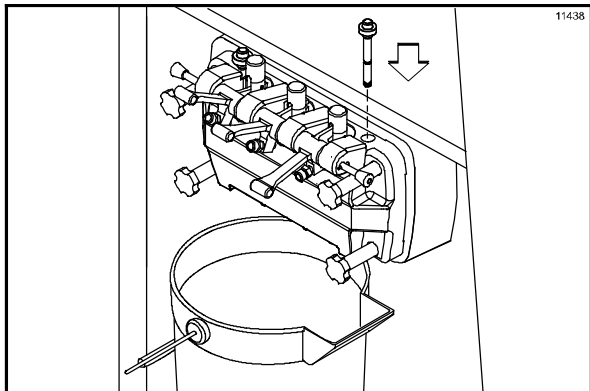

Figure 59

Step 9

Press the AUTO key. The MIX REF indicator will illuminate to indicate the mix refrigeration system is operating. The AUTO indicator will illuminate to indicate that the main refrigeration system is operating. The PUMP indicator will illuminate to indicate that the air/mix pump will operate whenever mix is needed in the freezing cylinder.

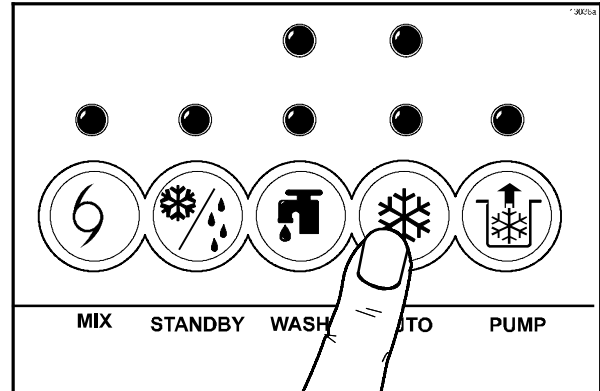

Figure 60

Repeat these steps for the other side of the freezer.

When the unit cycles off, the product will be at the correct viscosity.

Note: Keep the mix cabinet door closed except when filling the mix tank and during cleaning and sanitizing procedures. Leaving the door open while the mix refrigeration system is active may cause the evaporator to ice up and impair the mix cabinet refrigeration.

Closing Procedure

To disassemble the Model 8756, the following items will be needed:

- Two cleaning and sanitizing pails
- Necessary brushes (provided with freezer)
- Cleaner
- Single service towels

Draining Product From the Freezing Cylinder

Step 1

Press the AUTO and MIX REF keys to cancel freezer operation.

Step 2

Open the mix cabinet door and remove the mix storage cover, the mix tank cover, the mix tank, and the mix probe.

Step 3

If local health codes permit the use of rerun, empty the mix from the mix tank into a sanitized, NSF approved stainless steel rerun container. Place a sanitized lid on the rerun container and place it in the walk-in cooler.

Note: If local health codes DO NOT permit the use of rerun, the product must be discarded.

Step 4

Place the suction line in an empty pail in the mix cabinet.

Repeat these steps for the second freezing cylinder.



ALWAYS FOLLOW LOCAL HEALTH CODES.

Rinsing

Step 1

Fill the empty pail in the mix cabinet with two gallons (7.6 liters) of **cool**, clean water. Place the free end of the suction line in the pail of water.

Step 2

Disconnect the pressure line from the pressure switch and place it in the pail of water.

Step 3

Press the PUMP key. This action will cause the rinse water to be pumped through the air/mix pump and out through the pressure line. After approximately 15 seconds, press the PUMP key to stop operation.

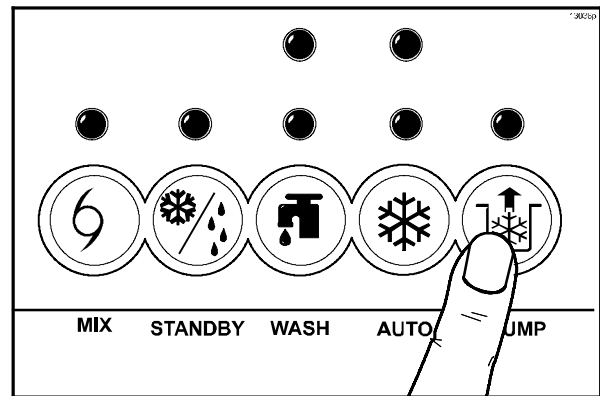

Figure 61

Step 4

Drain and connect the free end of the pressure line to the pressure switch.

Step 5

Place an empty pail beneath the door spout. Raise the prime plug and press the WASH and PUMP keys.

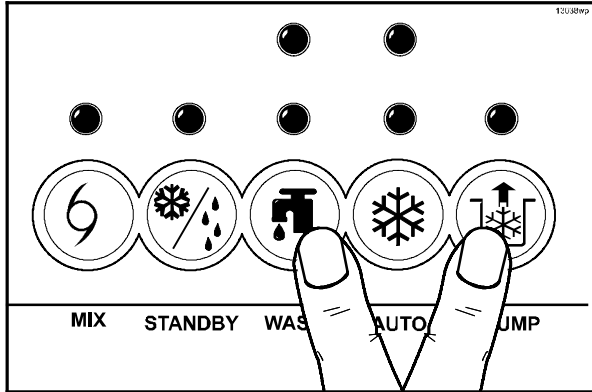

Figure 62

Step 6

When a steady stream of rinse water is flowing from the prime plug hole in the bottom of the freezer door, open the draw valve and drain all the rinse water.

Step 7

Once the rinse water stops flowing from the door spout, close the draw valve and press the WASH and PUMP keys to stop operation.

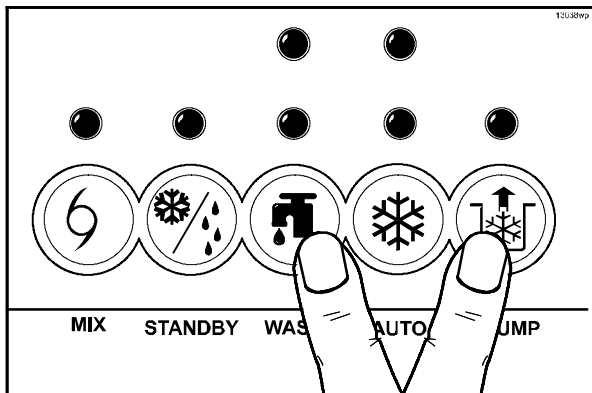

Figure 63

Step 8

Disconnect the pressure line from the pressure switch. Drain the water and then reconnect.

Step 9

Repeat this procedure using clean warm water, until the water being discharged is clear.

Repeat these steps for the second freezing cylinder.

Cleaning

Step 1

Prepare a pail of approved 100 PPM cleaning solution (examples: 2-1/2 gal. [9.5 liters] of Kay-5® or 2 gal. [7.6 liters] of Stera-Sheen®). USE WARM WATER AND FOLLOW THE MANUFACTURER'S SPECIFICATIONS.

Step 2

Place the pail of cleaning solution inside the mix cabinet and insert the suction line.

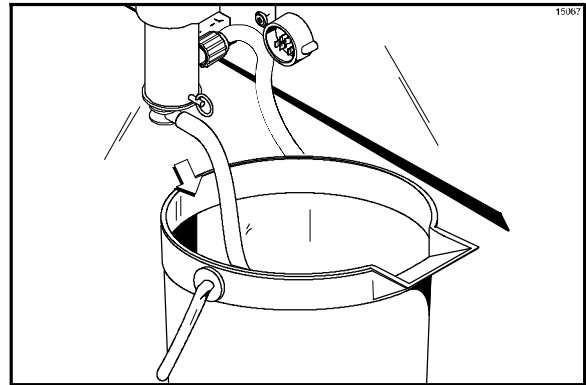

Figure 64

Step 3

Disconnect the pressure line from the pressure switch and place it in the pail of cleaning solution.

Step 4

Press the PUMP key. This action will cause the cleaning solution to be pumped through the air/mix pump and out through the pressure line. After approximately 15 seconds, press the PUMP key to stop operation.

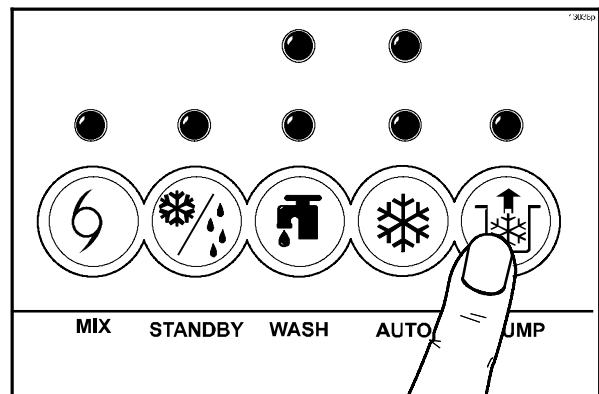

Figure 65

Step 5

Drain and connect the free end of the pressure line to the pressure switch.

Step 6

Place an empty pail beneath the door spout. Raise the prime plug and press the WASH and PUMP keys.

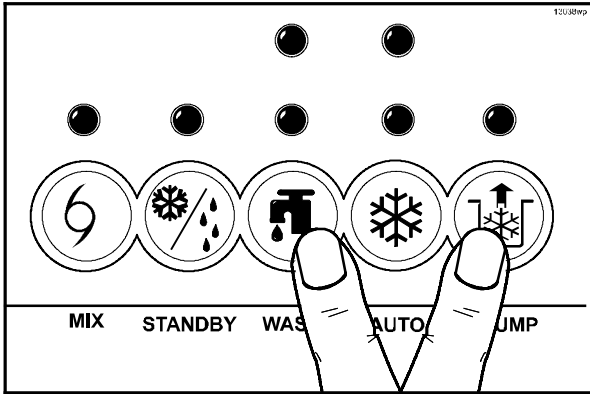

Figure 66

Step 7

When a steady stream of solution is flowing from the prime plug hole in the bottom of the freezer door, open the draw valve and draw off the remaining cleaning solution.

Step 8

Once the solution stops flowing from the door spout, close the draw valve and press the WASH and PUMP keys to stop operation.

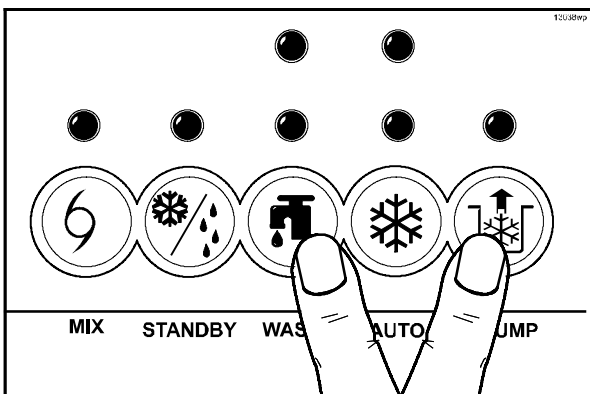

Figure 67

Repeat these steps for the other side of the freezer.

Step 9

Place the power switch in the OFF position before disassembling the machine.

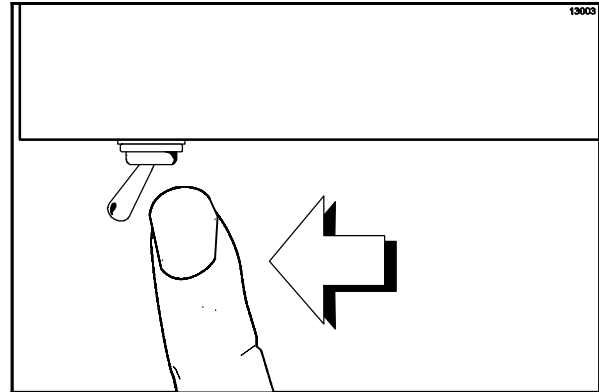

Figure 68

Disassembly



MAKE SURE THE POWER SWITCH IS IN THE "OFF" POSITION. Failure to follow this instruction may result in electrocution or injury to fingers or hands from hazardous moving parts.

Step 1

Remove the handscrews, freezer door, beaters, shoes, scraper blades and the drive shafts from the freezing cylinders. Take these parts to the sink for cleaning.

Step 2

Remove the air/mix pump. Unscrew the flare line from the mix inlet tube. Disengage the pressure line from the pressure switch and the mix inlet tube. Pull the retaining pin out of the pump collar and slide the collar down. Tilt the air/mix pump away from the machine and take the entire assembly to the sink for further disassembly and brush cleaning.

Step 3

Remove the pressure switch cap from the mix cabinet. Remove the diaphragm from the cap.

Repeat Steps 3 and 4 for the other side of the freezer.

Step 4

Remove the front drip tray and the splash shield.

Brush Cleaning

Step 1

Prepare a sink with an approved cleaning solution (examples: Kay-5® or Stera-Sheen®). USE WARM WATER AND FOLLOW THE MANUFACTURER'S SPECIFICATIONS.

If an approved cleaner other than Kay-5® or Stera-Sheen is used, dilute it according to the label instructions. **IMPORTANT:** Follow the label directions. Too STRONG of a solution can cause parts damage and too MILD of a solution will not provide adequate cleaning. Make sure all brushes provided with the freezer are available for brush cleaning.

Step 2

Remove the seals from the drive shafts.

Step 3

Remove the scraper blade clips from the scraper blades.

Step 4

From the freezer doors, remove the gaskets, front bearings, pivot pins, draw handles, draw valves, prime plugs, and design caps. Remove all o-rings.

Note: To remove the o-rings, use a single service towel to grasp the o-ring. Apply pressure in an upward direction until the o-ring pops out of its groove. With the other hand, push the top of the o-ring forward. It will roll out of the groove and can be easily removed. If there is more than one o-ring to be removed, always remove the rear o-ring first. This will allow the o-ring to slide over the forward rings without falling into the open grooves.

Step 5

Remove the flare lines, the suction lines, the retaining pins and the mix inlet fittings from the pump cylinders. Remove the liquid valve bodies from the pump cylinders.

Remove the pistons from the pump cylinders. Remove all o-rings and check bands.

Step 6

Return to the freezer with a small amount of cleaning solution. Use the black bristle brush to brush clean the rear shell bearings at the back of the freezing cylinders.

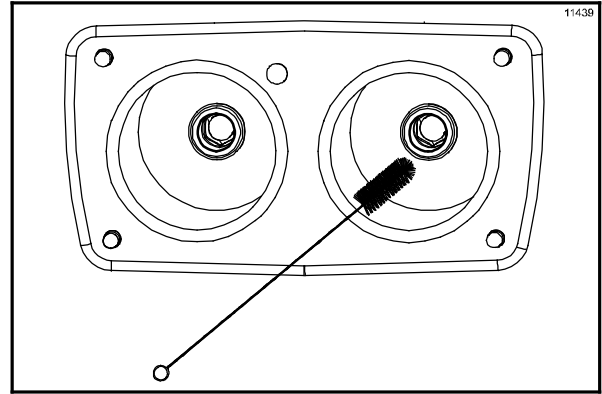

Figure 69

Step 7

Using the long, flexible brush and cleaning solution, clean the mix inlet tubes located in the mix cabinet. Thoroughly clean the tubes all the way up to the freezing cylinder. This area needs special attention because bacteria and milkstone can build up here.

Step 8

Remove the rear drip pan from the side panel and take it to the sink for cleaning.

Note: If the rear drip pan is filled with an excessive amount of mix, refer to the Troubleshooting Guide.

Step 9

Thoroughly brush clean all disassembled parts in the cleaning solution. Make sure all lubricant and mix film is removed. Take particular care to brush clean the draw valve cores in the freezer door.

Step 10

Place the parts on a clean, dry surface to air dry overnight.

Step 11

Wipe clean all exterior surfaces of the freezer and the mix cabinet.

Section 7 Important: Operator Checklist

During Cleaning and Sanitizing



ALWAYS FOLLOW LOCAL HEALTH CODES.

Cleaning and sanitizing schedules are governed by federal, state, or local regulatory agencies, and must be followed accordingly. If the unit has a “Standby mode”, it must not be used in lieu of proper cleaning and sanitizing procedures and frequencies set forth by the ruling health authority. The following check points should be stressed during the cleaning and sanitizing operations.



CLEANING AND SANITIZING MUST BE PERFORMED DAILY.

Troubleshooting Bacterial Count

- 1. Thoroughly clean and sanitize the machine regularly, including complete disassembly and brush cleaning.
- 2. Use all brushes supplied for thorough cleaning. The brushes are specially designed to reach all mix passageways.
- 3. Use the long white bristle brush to clean the mix feed tube which extends from the mix reservoir to the rear of the freezing cylinder.
- 4. Use the black bristle brush to thoroughly clean the rear shell bearing located at the rear of the freezing cylinder. Be sure there is a generous amount of cleaning solution on the brush.
- 5. Properly prepare the cleaning and sanitizing solutions. Read and follow the label directions carefully. Too strong of a solution may damage the parts and too weak of a solution will not do an adequate job of cleaning or sanitizing. Sanitize the freezing cylinder for 5 minutes.
- 6. The temperature of the mix in the mix cabinet and the walk-in cooler should be below 38°F (3.3°C).

Regular Maintenance Checks

- 1. Replace scraper blades that are bent, damaged or worn.
- 2. Before installing the beater, be certain that the scraper blades are properly attached over the pins and the beater assembly is straight.
- 3. Check the rear shell bearing for signs of wear (excessive mix leakage in the rear drip pan) and be certain it is properly cleaned.
- 4. Using a screwdriver and cloth towel, keep the rear shell bearing and the female hex drive socket clean and free of lubricant and mix deposits.
- 5. Dispose of o-rings and seals if they are worn, torn, or fit too loosely, and replace with new ones.
- 6. Follow all lubricating procedures as outlined in “Assembly”.

- 7. If your machine is air cooled, check the condensers for accumulation of dirt and lint. Dirty condensers will reduce the efficiency and capacity of the machine. Condensers should be cleaned **monthly** with a soft brush. **Never** use screwdrivers or other metal probes to clean between the fins.
Note: For machines equipped with an air filter, it will be necessary to vacuum the filters on a monthly schedule.
- 8. Your machine is equipped with an auxiliary refrigeration system. Check the auxiliary condenser for accumulation of dirt and lint. Dirty condensers will reduce the refrigeration capacity of the mix cabinet. Condensers must be cleaned **monthly** with a soft brush. **Never** use screwdrivers or other metal probes to clean between the fins.
- 9. On water cooled units, check the water lines for kinks or leaks. Kinks can occur when the machine is moved back and forth for cleaning or maintenance purposes.

The Air/Mix Pump

- 1. Dispose of the o-rings, the check bands and the pressure switch diaphragm if they are worn, torn or fit too loosely. Replace them with new ones.
- 2. Follow lubricating procedures carefully. **Never lubricate check bands.**
- 3. Handle plastic pump parts with care to avoid nicks and cracks.
- 4. Be sure the pressure line is securely attached to the pressure switch.
- 5. Clean, sanitize, and lubricate the pressure switch diaphragm daily.
- 6. Be sure the air/mix pump is properly aligned with the face plate of the motor reducer or severe and costly damage may occur.

Section 8

Troubleshooting Guide

PROBLEM	PROBABLE CAUSE	REMEDY	PAGE REF.
<p>1. No product is being dispensed.</p>	<ul style="list-style-type: none"> a. Low on mix. The MIX OUT light is on. b. The power switch is in the OFF position. c. The beater motor is out on reset. d. Insufficient mix in the freezing cylinder. e. Restriction in the door spout. f. Machine is unplugged. g. Circuit breaker is off or the fuse is blown. h. The mix probe was not installed properly or was damaged. i. The beater assembly is rotating counterclockwise. 	<ul style="list-style-type: none"> a. Add mix to the mix tank and press the AUTO key. b. Place the power switch in the ON position and press the AUTO key. c. Reset the freezer. d. Refer to problem #2. e. Disassemble and clean the freezer. Never put objects or fingers in the door spout. f. Plug machine into the wall receptacle. g. Turn the breaker on or replace the fuse. h. Check the mix probe installation. i. Contact a service technician to correct the rotation to clockwise. 	<p>28</p> <p>---</p> <p>13</p> <p>---</p> <p>---</p> <p>---</p> <p>---</p> <p>28</p> <p>---</p>
<p>2. Insufficient mix in the freezing cylinder.</p>	<ul style="list-style-type: none"> a. Suction line is not fully submerged in the mix. b. Improper seal of suction line to the mix inlet fitting. c. Worn or defective check bands or o-rings in air/mix pump assembly. 	<ul style="list-style-type: none"> a. Arrange the suction line so the weighted end is fully submerged. b. Remove the suction line from the mix inlet fitting. Place under hot running water, allow tubing to swell, then cool. Connect suction line to barbed fitting. Eventual replacement will be necessary. c. Replace regularly. Never lubricate check bands. 	<p>28</p> <p>---</p> <p>21 / 41</p>

PROBLEM	PROBABLE CAUSE	REMEDY	PAGE REF.
2. Insufficient mix in the freezing cylinder. <i>(Cont'd.)</i>	<ul style="list-style-type: none"> d. Missing, defective, or no lubrication on the mix inlet fitting o-ring. e. The pump motor is not activated. f. Pressure switch diaphragm installed incorrectly, or missing. g. The mix inlet tube is frozen or clogged. h. The mix pump ball crank is broken. i. Defective air/mix pump pressure switch. 	<ul style="list-style-type: none"> d. Replace or evenly lubricate the o-ring on the mix inlet fitting. e. Place power switch in OFF position. Push reset button on pump drive motor. Return power switch to ON position. Press the AUTO key. f. Diaphragm must be correctly installed in the pressure switch cap. g. Use the long flexible brush and sanitizing solution to clear the restriction in the mix inlet tube. Contact a service technician to correct the cause of over-refrigeration in the mix cabinet. h. Contact a service technician to replace the ball crank. i. Contact a service technician to replace the pressure switch. 	<ul style="list-style-type: none"> 23 / 41 --- 24 --- --- ---
3. Product is too stiff.	<ul style="list-style-type: none"> a. Insufficient mix in the freezing cylinder. b. Improper priming procedures. c. Out-of-date mix. d. Viscosity control is set too cold. 	<ul style="list-style-type: none"> a. Refer to problem #2. b. Drain the freezing cylinder and reprime the machine. c. Use fresh mix. d. Contact a service technician. 	<ul style="list-style-type: none"> 28 28/ 41 ---

PROBLEM	PROBABLE CAUSE	REMEDY	PAGE REF.
4. Product is too soft.	a. Worn scraper blades.	a. Replace scraper blades regularly.	41
	b. Dirty condensers or air filters on air cooled units.	b. Clean monthly.	35
	c. Inadequate water supply on water cooled units.	c. Check the water supply. Check water lines for leaks or kinks.	1/ 35
	d. Inadequate air space around air cooled units.	d. Allow adequate room for air flow across the condensers. Minimum of 3" (76 mm) clearance on all sides. Do not obstruct air discharge on top. 12" (305 mm) clearance on top of freezer.	1
	e. Viscosity control is set too warm.	e. Contact a service technician.	---
5. Mix in the mix cabinet is too warm.	a. Warm mix was placed in the tank.	a. Mix added to the mix tank should be below 40°F (4.4°C).	34
	b. The mix cabinet door was left open.	b. The door must be kept closed.	28
	c. The mix cabinet door gasket is not sealing.	c. Repair or replace gasket.	---
	d. Dirty mix cabinet condenser or air filter.	d. Clean monthly.	35
	e. The mix cabinet refrigeration system needs adjustment.	e. Contact a service technician.	---
6. Mix in the mix cabinet is too cold.	a. The mix cabinet refrigeration system needs adjustment.	a. Contact a service technician.	---
7. Excessive mix leakage from the bottom of the door spout.	a. Worn, missing or incorrect o-ring is on the draw valve.	b. Check the o-rings. (Replace every 3 months.)	41
	b. Improper lubrication on the draw valve o-rings.	c. Lubricate properly.	19

PROBLEM	PROBABLE CAUSE	REMEDY	PAGE REF.
8. Excessive mix leakage into the rear drip pan.	a. Worn or missing drive shaft seal.	a. Install or replace the seal.	16/ 41
	b. Improper lubrication of the drive shaft.	b. Lubricate properly.	16
	c. Worn rear shell bearing.	c. Contact a service technician to replace the rear shell bearing.	---
	d. The gear box is out of alignment.	d. Contact a service technician to align the gear box.	---
9. The drive shaft is stuck in the gear box coupling.	a. Rounded corners on hex end of drive shaft or gear coupling.	a. Replace damaged component.	---
	b. The gear box is out of alignment.	b. Contact a service technician to align the gear box.	---
10. Freezing cylinder walls are scored.	a. Broken pins on beater assembly.	a. Repair or replace the beater assembly. Be sure the scraper blades are properly seated on pins.	17
	b. Missing front bearing.	b. Install the front bearing on the back of the freezer door.	18
	c. The beater assembly is bent.	c. Repair or replace the beater assembly. Contact a service technician to correct the cause of insufficient mix in freezing cylinder.	---
11. The air/mix pump does not operate.	a. The pump motor is not activated.	a. Place power switch in OFF position. Push reset button on pump drive motor. Place power switch in ON position.	---
	b. The pressure switch diaphragm was installed incorrectly or is missing.	b. The diaphragm must be correctly installed in the pressure switch cap.	24
	c. Defective air/mix pump pressure switch.	c. Contact a service technician to replace the pressure switch.	---

PROBLEM	PROBABLE CAUSE	REMEDY	PAGE REF.
12. The machine will not operate in the AUTO mode.	a. The machine is unplugged.	a. Plug the machine into the wall receptacle.	---
	b. The circuit breaker is off or the fuse is blown.	b. Turn the breaker on or replace the fuse.	---
	c. Low on mix. The MIX OUT light is flashing.	c. Add mix to the mix tank and press the AUTO key.	13
	d. The mix probe is not installed properly or is damaged.	d. Check the mix probe installation.	28
	e. The beater motor is out on reset.	e. Reset the freezer.	13
	f. The power switch is in the OFF position.	f. Place the power switch in the ON position.	25
	g. The unit is off on high head pressure.	g. Air cooled: clean the condenser. Water cooled: check the water supply. Contact a service technician.	35
13. Overrun is too low.	a. The air orifice is plugged.	a. Use a soap solution to clean the small hole in the air orifice.	---
14 Air is "popping" during the dispensing of product.	a. Incorrect assembly of the air/mix pump.	a. Assemble and lubricate the air/mix pump components according to instructions.	21
	b. The mix suction line is losing its prime.	b. The mix suction line is cracked or has a loose fit to the mix inlet fitting. Replace the mix suction line.	---

Section 9

Parts Replacement Schedule

PART DESCRIPTION	EVERY 3 MONTHS	EVERY 6 MONTHS	ANNUALLY
Scraper Blades	X		
Drive Shaft Seal	X		
Freezer Door Gasket	X		
Front Bearing	X		
Beater Shoes	X		
Draw Valve O-Rings	X		
Prime Plug O-Rings	X		
Air/Mix Pump O-Rings	X		
Check Rings	X		
Mix Inlet Fitting O-Ring	X		
Pressure Switch Diaphragm	X		
Design Cap	X		
Black Bristle Brush, 1" x 2"		Inspect & Replace if Necessary	Minimum
Double Ended Brush		Inspect & Replace if Necessary	Minimum
White Bristle Brush, 1" x 2"		Inspect & Replace if Necessary	Minimum
White Bristle Brush, 9/16" x 44"		Inspect & Replace if Necessary	Minimum
White Bristle Brush, 3" x 7"		Inspect & Replace if Necessary	Minimum
Small White Bristle Brush, 1/8"		Inspect & Replace if Necessary	Minimum
Brush Set		Inspect & Replace if Necessary	Minimum

Section 10 Limited Warranty on Equipment

TAYLOR COMPANY LIMITED WARRANTY ON FREEZERS

Taylor Company, a division of Carrier Commercial Refrigeration, Inc. (“Taylor”) is pleased to provide this limited warranty on new Taylor-branded freezer equipment available from Taylor to the market generally (the “Product”) to the original purchaser only.

LIMITED WARRANTY

Taylor warrants the Product against failure due to defect in materials or workmanship under normal use and service as follows. All warranty periods begin on the date of original Product installation. If a part fails due to defect during the applicable warranty period, Taylor, through an authorized Taylor distributor or service agency, will provide a new or re-manufactured part, at Taylor’s option, to replace the failed defective part at no charge for the part. Except as otherwise stated herein, these are Taylor’s exclusive obligations under this limited warranty for a Product failure. This limited warranty is subject to all provisions, conditions, limitations and exclusions listed below and on the reverse (if any) of this document.

Product	Part	Limited Warranty Period
Soft Serve	Insulated shell assembly	Five (5) years
Frozen Yogurt Shakes	Refrigeration compressor (except service valve)	Five (5) years
Smoothies	Beater motors	Two (2) years
Frozen Beverage	Beater drive gear	Two (2) years
Batch Desserts	Printed circuit boards and Softech controls beginning with serial number H8024200	Two (2) years
	Parts not otherwise listed in this table or excluded below	One (1) year

LIMITED WARRANTY CONDITIONS

1. If the date of original installation of the Product cannot be verified, then the limited warranty period begins ninety (90) days from the date of Product manufacture (as indicated by the Product serial number). Proof of purchase may be required at time of service.
2. This limited warranty is valid only if the Product is installed and all required service work on the Product is performed by an authorized Taylor distributor or service agency, and only if genuine, new Taylor parts are used.
3. Installation, use, care, and maintenance must be normal and in accordance with all instructions contained in the Taylor Operator’s Manual.
4. Defective parts must be returned to the authorized Taylor distributor or service agency for credit.
5. The use of any refrigerant other than that specified on the Product’s data label will void this limited warranty.

LIMITED WARRANTY EXCEPTIONS

This limited warranty does **not** cover:

1. Labor or other costs incurred for diagnosing, repairing, removing, installing, shipping, servicing or handling of defective parts, replacement parts, or new Products.
2. Normal maintenance, cleaning and lubrication as outlined in the Taylor Operator’s Manual, including cleaning of condensers.

3. Replacement of wear items designated as Class "000" parts in the Taylor Operator's Manual.
4. External hoses, electrical power supplies, and machine grounding.
5. Parts not supplied or designated by Taylor, or damages resulting from their use.
6. Return trips or waiting time required because a service technician is prevented from beginning warranty service work promptly upon arrival.
7. Failure, damage or repairs due to faulty installation, misapplication, abuse, no or improper servicing, unauthorized alteration or improper operation or use as indicated in the Taylor Operator's Manual, including but not limited to the failure to use proper assembly and cleaning techniques, tools, or approved cleaning supplies.
8. Failure, damage or repairs due to theft, vandalism, wind, rain, flood, high water, water, lightning, earthquake or any other natural disaster, fire, corrosive environments, insect or rodent infestation, or other casualty, accident or condition beyond the reasonable control of Taylor; operation above or below the electrical or water supply specification of the Product; or components repaired or altered in any way so as, in the judgment of the Manufacturer, to adversely affect performance, or normal wear or deterioration.
9. Any Product purchased over the Internet.
10. Failure to start due to voltage conditions, blown fuses, open circuit breakers, or damages due to the inadequacy or interruption of electrical service.
11. Electricity or fuel costs, or increases in electricity or fuel costs from any reason whatsoever.
12. Damages resulting from the use of any refrigerant other than that specified on the Product's data label will void this limited warranty.
13. Any cost to replace, refill or dispose of refrigerant, including the cost of refrigerant.
14. **ANY SPECIAL, INDIRECT OR CONSEQUENTIAL PROPERTY OR COMMERCIAL DAMAGE OF ANY NATURE WHATSOEVER.** Some jurisdictions do not allow the exclusion of incidental or consequential damages, so this limitation may not apply to you.

This limited warranty gives you specific legal rights, and you may also have other rights which vary from jurisdiction to jurisdiction.

LIMITATION OF WARRANTY

THIS LIMITED WARRANTY IS EXCLUSIVE AND IS IN LIEU OF ALL OTHER WARRANTIES, CONDITIONS AND/OR REMEDIES UNDER THE LAW, INCLUDING ANY IMPLIED WARRANTIES OR CONDITIONS OF MERCHANTABILITY OR FITNESS FOR A PARTICULAR PURPOSE. THE ORIGINAL OWNER'S SOLE REMEDY WITH RESPECT TO ANY PRODUCTS SHALL BE REPAIR OR REPLACEMENT OF DEFECTIVE COMPONENTS UNDER THE TERMS OF THIS LIMITED WARRANTY. ALL RIGHTS TO CONSEQUENTIAL OR INCIDENTAL DAMAGES (INCLUDING CLAIMS FOR LOST SALES, LOST PROFITS, PRODUCT LOSS, PROPERTY DAMAGES OR SERVICE EXPENSES) ARE EXPRESSLY EXCLUDED. THE EXPRESS WARRANTIES MADE IN THIS LIMITED WARRANTY MAY NOT BE ALTERED, ENLARGED, OR CHANGED BY ANY DISTRIBUTOR, DEALER, OR OTHER PERSON, WHATSOEVER.

LEGAL REMEDIES

The owner **must** notify Taylor in writing, by certified or registered letter to the following address, of any defect or complaint with the Product, stating the defect or complaint and a specific request for repair, replacement, or other correction of the Product under warranty, mailed at least thirty (30) days before pursuing any legal rights or remedies.

Taylor Company
a division of Carrier Commercial Refrigeration, Inc.
750 N. Blackhawk Blvd.
Rockton, IL 61072, USA

Section 11

Limited Warranty on Parts

TAYLOR COMPANY LIMITED WARRANTY ON TAYLOR GENUINE PARTS

Taylor Company, a division of Carrier Commercial Refrigeration, Inc. ("Taylor") is pleased to provide this limited warranty on new Taylor genuine replacement components and parts available from Taylor to the market generally (the "Parts") to the original purchaser only.

LIMITED WARRANTY

Taylor warrants the Parts against failure due to defect in materials or workmanship under normal use and service as follows. All warranty periods begin on the date of original installation of the Part in the Taylor unit. If a Part fails due to defect during the applicable warranty period, Taylor, through an authorized Taylor distributor or service agency, will provide a new or re-manufactured Part, at Taylor's option, to replace the failed defective Part at no charge for the Part. Except as otherwise stated herein, these are Taylor's exclusive obligations under this limited warranty for a Part failure. This limited warranty is subject to all provisions, conditions, limitations and exclusions listed below and on the reverse (if any) of this document.

Part's Warranty Class Code or Part	Limited Warranty Period
Class 103 Parts ¹	Three (3) months
Class 212 Parts ²	Twelve (12) months
Class 512 Parts	Twelve (12) months
Class 000 Parts	No warranty
Taylor Part #072454 (Motor-24VDC *C832/C842*)	Four (4) years

LIMITED WARRANTY CONDITIONS

1. If the date of original installation of the Part cannot be otherwise verified, proof of purchase may be required at time of service.
2. This limited warranty is valid only if the Part is installed and all required service work in connection with the Part is performed by an authorized Taylor distributor or service agency.
3. The limited warranty applies only to Parts remaining in use by their original owner at their original installation location in the unit of original installation.
4. Installation, use, care, and maintenance must be normal and in accordance with all instructions contained in the Taylor Operator's Manual.
5. Defective Parts must be returned to the authorized Taylor distributor or service agency for credit.
6. This warranty is not intended to shorten the length of any warranty coverage provided pursuant to a separate Taylor Limited Warranty on freezer or grill equipment.
7. The use of any refrigerant other than that specified for the unit in which the Part is installed will void this limited warranty.

^{1, 2} Except that Taylor Part #032129SER2 (Compressor-Air-230V SERV) and Taylor Part #075506SER1 (Compressor-Air-115V 60HZ) shall have a limited warranty period of twelve (12) months when used in Taylor freezer equipment and a limited warranty period of two (2) years when used in Taylor grill equipment.

LIMITED WARRANTY EXCEPTIONS

This limited warranty does **not** cover:

1. Labor or other costs incurred for diagnosing, repairing, removing, installing, shipping, servicing or handling of defective Parts, replacement Parts, or new Parts.
2. Normal maintenance, cleaning and lubrication as outlined in the Taylor Operator's Manual, including cleaning of condensers or carbon and grease buildup.
3. Required service, whether cleaning or general repairs, to return the cooking surface assemblies, including the upper platen and lower plate, to an operational condition to achieve proper cooking or allow proper assembly of release sheets and clips as a result of grease build-up on the cooking surfaces, including but not limited to the platen and plate, sides of the shroud or top of the shroud.
4. Replacement of cooking surfaces, including the upper platen and lower plate, due to pitting or corrosion (or in the case of the upper platen, due to loss of plating) as a result of damage due to the impact of spatulas or other small wares used during the cooking process or as a result of the use of cleaners, cleaning materials or cleaning processes not approved for use by Taylor.
5. Replacement of wear items designated as Class "000" Parts in the Taylor Operator's Manual, as well as any release sheets and clips for the Product's upper platen assembly.
6. External hoses, electrical power supplies, and machine grounding.
7. Parts not supplied or designated by Taylor, or damages resulting from their use.
8. Return trips or waiting time required because a service technician is prevented from beginning warranty service work promptly upon arrival.
9. Failure, damage or repairs due to faulty installation, misapplication, abuse, no or improper servicing, unauthorized alteration or improper operation or use as indicated in the Taylor Operator's Manual, including but not limited to the failure to use proper assembly and cleaning techniques, tools, or approved cleaning supplies.
10. Failure, damage or repairs due to theft, vandalism, wind, rain, flood, high water, water, lightning, earthquake or any other natural disaster, fire, corrosive environments, insect or rodent infestation, or other casualty, accident or condition beyond the reasonable control of Taylor; operation above or below the gas, electrical or water supply specification of the unit in which a part is installed; or Parts or the units in which they are installed repaired or altered in any way so as, in the judgment of Taylor, to adversely affect performance, or normal wear or deterioration.
11. Any Part purchased over the Internet.
12. Failure to start due to voltage conditions, blown fuses, open circuit breakers, or damages due to the inadequacy or interruption of electrical service.
13. Electricity, gas or other fuel costs, or increases in electricity or fuel costs from any reason whatsoever.
14. Damages resulting from the use of any refrigerant other than that specified for the unit in which the Part is installed will void this limited warranty.
15. Any cost to replace, refill or dispose of refrigerant, including the cost of refrigerant.
16. **ANY SPECIAL, INDIRECT OR CONSEQUENTIAL PROPERTY OR COMMERCIAL DAMAGE OF ANY NATURE WHATSOEVER.** Some jurisdictions do not allow the exclusion of incidental or consequential damages, so this limitation may not apply to you.

This limited warranty gives you specific legal rights, and you may also have other rights which vary from jurisdiction to jurisdiction.

LIMITATION OF WARRANTY

THIS LIMITED WARRANTY IS EXCLUSIVE AND IS IN LIEU OF ALL OTHER WARRANTIES, CONDITIONS AND/OR REMEDIES UNDER THE LAW, INCLUDING ANY IMPLIED WARRANTIES OR CONDITIONS OF MERCHANTABILITY OR FITNESS FOR A PARTICULAR PURPOSE. THE ORIGINAL OWNER'S SOLE REMEDY WITH RESPECT TO ANY PRODUCTS SHALL BE REPAIR OR REPLACEMENT OF DEFECTIVE PARTS UNDER THE TERMS OF THIS LIMITED WARRANTY. ALL RIGHTS TO CONSEQUENTIAL OR INCIDENTAL DAMAGES (INCLUDING CLAIMS FOR LOST SALES, LOST PROFITS, PRODUCT LOSS, PROPERTY DAMAGES OR SERVICE EXPENSES) ARE EXPRESSLY EXCLUDED. THE EXPRESS WARRANTIES MADE IN THIS LIMITED WARRANTY MAY NOT BE ALTERED, ENLARGED, OR CHANGED BY ANY DISTRIBUTOR, DEALER, OR OTHER PERSON, WHATSOEVER.

LEGAL REMEDIES

The owner **must** notify Taylor in writing, by certified or registered letter to the following address, of any defect or complaint with the Part, stating the defect or complaint and a specific request for repair, replacement, or other correction of the Part under warranty, mailed at least thirty (30) days before pursuing any legal rights or remedies.

Taylor Company
a division of Carrier Commercial Refrigeration, Inc.
750 N. Blackhawk Blvd.
Rockton, IL 61072, USA

Section 12

Parts List

DESCRIPTION	PART NUMBER	QTY.	WARR. CLASS	REMARKS
ADAPTOR-PUMP-CABINET	024259	2	103	
BEARING-REAR SHELL-NICKEL	031324	2	000	
+GUIDE-DRIP SEAL	028992	2	000	
+NUT-BRASS BEARING	028991	2	000	
+WASHER-BEARING LOCK	012864	2	000	
BEATER A.-3.4QT-1 PIN-SUPPORT	X46231	2	103	
+BLADE-SCRAPER-PLASTIC	046235	4	000	
+CLIP-SCRAPER BLADE	046236	4	103	
BEARING-FRONT-SHOE	050348	-->	000	ORDER X50350 SHOE KIT
BELT-AX36	022849	4	000	
BLOCK-TERMINAL	039423	4	103	208-230V 60HZ 3PH
BLOWER A.-STANDARD OUTPUT	X53725-27	1	103	
CAPACITOR-RUN 7.5UF/370V	034749	1	103	
BOOT-CAPACITOR-INSULATING	031314	1	000	
MOTOR-FAN 208-230V 50/60 HZ	053481-27	1	103	
BOARD-LOGIC-GEN	X36641SER2	2	212	
BOARD-POWER-GEN 1 & 2	X32326-SER	2	212	
BOOT-PRESSURE SWITCH	032624	2	000	
BRACKET A.-RESET BUTTON	X22004	2	103	
+PIN-PIVOT	013592	2	103	
+EYELET-RESET BUTTON	013739	2	103	
BRUSH-REAR BRG 1" D X 2" LONG X 14	013071	1	000	
BRUSH-DOUBLE ENDED	013072	1	000	
BRUSH-DRAW VALVE 1" OD X 2" X 17" L	013073	1	000	
BRUSH-FEED TUBE 9/16 OD	021101	1	000	
BRUSH-MIX PUMP BODY-3" X 7" WHITE	023316	1	000	
BRUSH-PRESSURE SWITCH	027647	2	000	
BRUSH-SET	050103	1	000	
CABLE A.-2 COND-24 IN-PUSH ON	X34464	1	000	
CABLE-RIBBON-POWER/RELAY-18 IN	032444	2	103	

+ Available Separately

DESCRIPTION	PART NUMBER	QTY.	WARR. CLASS	REMARKS
CAP-DESIGN-1.010"ID-6 POINT	014218	3	000	
CAP-PUMP	021276-9	2	103	
CASTER-SWV-3/4-10 ST. 3IN WHEEL	021279	2	103	
CASTER-3" SWV 3/4-10 STM W/BRAKE	030307	2	103	
COMPRESSOR L63A113DBLA	048259-33	2	512	208-230V 60HZ 3PH - 3
COMPRESSOR AEA0415ZXD-AE580ET	048627-27	1	512	MIX CABINET 208-230V 60HZ 1PH & 208-230V 60HZ 3PH
+CAPACITOR-RUN 7.5UF/370V	034749	1	103	
+RELAY-START-COMPRESSOR	050106-27	1	103	
CONTROL A.-LOW VOLTAGE PUMP	X65954	1	103	
+BRACKET-PUMP CIRCUIT MOUNT	065955	1	103	
+RELAY-DPDT-24VAC-30A@277V	054703-03	1	103	LOW VOLTAGE CONTROL PUMP
+TRANS.-CONT.-ANTICIPATOR 20	016352-27	1	103	LOW VOLTAGE CONTROL PUMP
CONDENSER-AC-18LX14H-4ROW - NEW	050104	2	103	MAIN
CONDENSER-AC-9X8 -2 ROW	029797	1	103	MIX CABINET
COUPLING-DRIVE 3/4 HEX X 1-7/8	012721	2	103	
+SCREW-5/16-18 X 5/16 ALLEN SET	042511	4	000	
COVER-PUMP CONTROL	065956	2	000	
COVER-MIX TANK	024590	1	103	
COVER-MIX STORAGE-LEFT	037138	1	103	
COVER- MIX STORAGE-RIGHT	037139	1	103	
+BOOT-MIX COVER	037200	2	000	
COMPRESSOR L63A113BBC2 (BRISTOL-OLD)	048259-27	*	512	MAIN - 8752-PRIOR TO J9066372
+CAPACITOR-RUN 20UF/440V	012906	*	103	8756-PRIOR TO J9013732 - 230-60-1
+CAPACITOR-START - 161-193UF/250V	031790	*	103	230-60-1 - BRISTOL
+RELAY-START COMPRESSOR	038145	*	103	230-60-1 - BRISTOL
COMPRESSOR CS18K6E-PFV (COPELAND)	052397-	*	512	MAIN - 8752-J9066372/UP, 8756-J9013732/UP
+CAPACITOR-RUN- 35UF-370V	029439	*	103	230-60-1
+CAPACITOR-START-216-259UF-250V	031304	*	103	230-60-1
+RELAY-START-COMPRESSOR	052401-27	*	103	230-60-1
+KIT-MOUNTING-COMPRESSOR	052197	*	000	
DECAL-DEC-TAYLOR-TWIN-SS-CABINET	032424	1	000	

+ Available Separately

DESCRIPTION	PART NUMBER	QTY.	WARR. CLASS	REMARKS
DECAL-DOOR-3 SPOUT-TWIN TWIST	021521	1	000	
DECAL-INST-CLN-CAB	024735	1	000	
DECAL-MIX TANK-WRONG	038750	2	000	
DECAL-TROUBLESHOOT	038374	1	000	
DIAGRAM-WIRING	037807-33	1	000	
DOOR A.-3 SPOUT	X51532-12	1	103	
DECAL-DOOR-3 SPOUT-TWIN TWIST	021521	1	000	
+GASKET-DOOR-4" SHELL	048926	2	000	
+HANDLE A.-DRAW ADJUSTABLE	X55096	3	103	
+O-RING-1/4 OD X .070 W 50	015872	3	000	
+SCREW-ADJUSTMENT-STAINLESS	033662	3	000	
+NUT-5/16-24 18-8 SS JAM	029639-BLK	3	000	
+KIT A.-BEATER-FRONT SHOES	X50350	2	000	
BEARING-FRONT-SHOE	050348	2	000	
SHOE-FRONT HELIX *REAR*	050346	2	000	
SHOE-FRONT HELIX *FRONT*	050347	2	000	
+PLUG-PRIME	028805	2	103	
+O-RING-3/8 OD X .070W	016137	4	000	PRIME PLUG
+ROD A.-PIVOT	X22388	1	103	SHORT
+O-RING-5/16 OD X .070W	016272	2	000	PIVOT ROD
+ROD A.-PIVOT	X22387	1	103	LONG
+O-RING-5/16 OD X .070W	016272	2	000	PIVOT ROD
+VALVE A.-DRAW	X18303	2	103	
+O-RING-7/8 OD X .103W	014402	5	000	DRAW VALVE
DOOR A.-INS.MIX	X24816	1	103	
DRYER-CAP. TUBE	049346	1	000	MIX CABINET
DRYER-FILTER	048901	2	000	MAIN
DVD-OPS TRAIN VIDEO	038417-DVD	1	000	
EVAPORATOR-12L X 4H X 1-7/8T	X30939	1	103	MIX CABINET
FASTENER-CLIP 1/4-20 U TYPE 8	045865	8	000	PANELS
FITTING DOOR INTERLOCK	065471	1	103	

+ Available Separately

DESCRIPTION	PART NUMBER	QTY.	WARR. CLASS	REMARKS
FITTING-INLET	013087	2	103	
FUNNEL-MIX	036637	2	103	
FUSE-15 AMP CARTRIDGE	027582	4	000	
FUSE-.063A-250V-5X20MM	051272	2	103	
FUSE-15 AMP CARTRIDGE	027582	2	000	
GASKET-CAB MIX DOOR	024629	1	000	
GASKET-DOOR HT 4"-DOUBLE	048926	2	000	
GEAR A.*REDUCER	021286-SER	2	212	
GUARD-FAN	028534-1	2	103	MIX CABINET
GUIDE A.-DRIP PAN	X28628	1	103	
HARNES A.-TRANS/RELAY	068529-27	1		
HINGE A.-MOTOR	X25736	2	103	
HINGE-SELF CLOSING DOOR	020143	1	103	
+BEARING A.-HINGE	X20305	1	000	
+CAP-DOOR	032934	1	000	
+PIN A.-UPPER HINGE	X20315	1	103	
+PLATE-LOWER HINGE	020323	1	103	
+SPACER-HINGE	020741	2	000	
+SHIM-DOOR	036023	2	103	
+SUPPORT A.-HINGE	X32521	1	103	
HOLDER-FUSE 300 VOLT PANEL MOUNT	027581	4	103	
HOOD	048526	1	103	
KIT A.-BEATER-FRONT SHOES	X50350	1	000	
KIT A.-MOTOR-FAN	X62253-27	2	103	MIX CABINET
KIT A.-TUNE UP-3 SPOUT-CAB	X49463-2	1	000	
DIAPHRAGM-PRESSURE SWITCH	020249	2		
KIT A.-BARREL *TWIN SS	X56200-6	1		
CAP-DESIGN 1.010"ID-6 POINT	014218	3		
O-RING-7/8 OD X .103W	014402	7		
O-RING-5/16 OD X .070W	016272	2		
SEAL-DRAW VALVE	034698	1		

+ Available Separately

DESCRIPTION	PART NUMBER	QTY.	WARR. CLASS	REMARKS
KIT A.-DRAW VALVE *TWIN SS*	X56200-3	1		
GASKET-DOOR HT 4"-DOUBLE	048926	2		
SEAL-DRIVE SHAFT	032560	2		
KIT A.-BEATER-FRONT SHOES	X50350	2		
BEARING-FRONT-SHOE	050348	2		
SHOE-FRONT HELIX *FRONT*	050347	2		
SHOE-FRONT HELIX *REAR*	050346	2		
O-RING-13/16 OD X .139W	021278	2		
O-RING-1-3/8 OD X .103W-#123	018664	2		
O-RING-2-1/8 OD X .139W-#225	020051	6		
O-RING-3/8 OD X .070W	016137	4		
POPPET-RUBBER-BLACK	022473	2		
RING-CHECK 1-1/4 OD X 3/8	033215	2		
RING-CHECK 2 IN OD X 1/2	020050	4		
TOOL-O-RING REMOVAL-FREEZER	048260-WHT	1		
LABEL-CHECK MOTOR ROTATATION	020090	1	000	208-230V 60HZ 3PH
LABEL-DOOR-WARNING-MOVING PARTS	032749	1	000	
LABEL-WARNING-COVER	051433	7	000	
LABEL-SWITCH-POWER-OFF/ON	052632	1	000	
LINE A.-PUMP PRESSURE	X27139	2	103	
FERRULE-3/8 OD BRASS	030553	4	000	
SOCKET-QD. 3/16 BARB	020021	4	103	
TUBE-VINYL 3/16 ID X 1/16	020940-16	2	000	R30314 TUBE-VINYL 3/16IDX5/16OD-100'R
LINE A.-FLARE 15"	038299	2	103	
LUBRICANT-TAYLOR 4 OZ.	047518	1	000	36 TUBES PER CASE
MAN-OPER 8752/8756/8757	028752-M	1	000	
MOTOR-1.5 HP	021522-33	2	212	
MOTOR-FAN 95.3 CFM 2700 RPM	062253-27	2	103	ORDER X62253-27 KIT A.-MOTOR-FAN KIT A.-MOTOR
+GUARD-FAN	028534-1	2	103	
MOTOR-FAN 208-230V 50/60 HZ	053481-27	1	103	BLOWER
MOTOR-REDUCER 54 RPM-SS	03091327AS	2	103	

+ Available Separately

DESCRIPTION	PART NUMBER	QTY.	WARR. CLASS	REMARKS
NUT-STUD *LONG	034382	2	103	
NUT-STUD *SHORT	034383	2	103	
ORIFICE	023425-50	2	103	
+O-RING-13/16 OD X .103W	019330	2	000	
PAIL-10 QT.	013163	2	000	
PAN A.-DRIP	X22811	1	103	EXPANSION VALVE
PAN-DRIP 17-1/4"LONG	027504	1	103	
PANEL A.-FRONT	X22879	1	103	
PANEL A.-LOWER SIDE	X23956	2	103	RIGHT & LEFT
PANEL-LOWER REAR	023598	1	103	
PANEL-UPPER REAR	022015	1	103	
PANEL-UPPER SIDE LEFT	028599	1	103	HINGED
PANEL-UPPER SIDE RIGHT	028600	1	103	HINGED
+WASHER-PLASTIC PIVOT	013808	4	000	
PIN-RETAINING	021276-8	2	103	
PLATE A.-DEC.	X32138	1	103	
PLUG-DRIP TRAY HOLE	029595	1	000	
PLUG-HOLE 1/2	034878	1	000	
PROBE A.-MIX-W/BALL CONNECTORS	X35981	2	103	MIX CABINET
PROBE A.-THERMISTOR	X31602	2	103	BARREL
PROBE A.-THERMISTOR *SHORT*	X36267	1	103	MIX CABINET
PULLEY-2AK22 X .625-.6265	016403	2	103	
PULLEY-2AK74-5/8	027822	2	103	GEAR
PUMP A.-SOFT SERVE *CABINET*	X22345	2	103	
BODY A.-VALVE	X22345-3	2	103	
CYLINDER A.-PUMP	022345-1	2	103	
ELBOW-INLET 90 DEG.	022502-4	2	103	
O-RING-13/16 OD X .139W	021278	2	000	
O-RING-2-1/8 OD X .139W-#225	020051	6	000	
PIN-RETAINING	021276-8	2	103	
PISTON	021276-2	2	103	

DESCRIPTION	PART NUMBER	QTY.	WARR. CLASS	REMARKS
RING-CHECK 2 IN OD X 1/2	020050	6	000	
+CAP-PUMP	021276-9	2	103	
+PIN-RETAINING	021276-8	2	103	
RELAY-3 POLE-20A-208/240 50/60	066795-33	2	103	
RELAY-DPDT 100UA TO 7A 1/8HP	052111-03	1	103	
RELAY-DPDT-24VAC-30A@277V	054703-03	2	103	
RELAY-MTR START TI#4CR-2-645	042007-34	2	103	
RELAY-SPST-30 A-240V	032607-27	1	103	
RELAY-START-COMPRESSOR	050106-27	1	103	
SANITIZER-STERA SHEEN-GREEN	055492	1	000	100/20Z. PACKETS PER CASE
SANITIZER-STERA SHEEN GREEN	010425	1	000	64 OZ. PER JAR
SHAFT-BEATER	032564	2	103	
+SEAL-DRIVE SHAFT	032560	2	000	
SHELL A.-INSULATED	X24347-SER	1	512	
STUD-NOSE CONE	068410	4	103	
SHIELD-SPLASH 23 INCH	022766	1	103	
SHROUD-CONDENSER *REAR	048517	1	103	
SHROUD-CONDENSER *TOP	048518	1	103	
SHROUD-CONDENSER *FRONT	048519	1	103	
SHROUD A.-EVAPORATOR	X49124	1	103	
SPRING-COMP.970X.115X2.00	025707	4	103	
SPRING-RETURN RIGHT	023488	1	103	
SPRING-RETURN LEFT	023487	1	103	
SPRING-COMP.480X.047X1.00	032651	2	103	
SPRING-INTERLOCK DOOR	065409	1	000	
SOCKET A.-PROBE*BALL&SOCK*60IN	X36615	2	103	
CLIP-BALL CONNECTOR	035813	6	000	
SCREW-5-40 X 1/4 SOCKET CAP SS	037843	6	000	
STARTER-3 PHASE 4 TO 6.5 AMP	066794-33J	2	103	
OVERLOAD-THERMAL-3P-4-0/6.5A	067461-3J	2	103	
STRIP-TOP TRIM	024827	1	103	

+ Available Separately

DESCRIPTION	PART NUMBER	QTY.	WARR. CLASS	REMARKS
SWITCH A.-DRAW *TWIN TWIST	X38921	1	103	
ARM-SWITCH-DRAW-LEFT	038649	1	103	
ARM-SWITCH-DRAW-RIGHT	038650	1	103	
BRACKET A.-SWITCH	X38252	1	103	
E-RING 1/4	032190	2	000	
PIN-PIVOT-DRAW SWITCH	038484	1	103	
SPRING-RETURN LEFT	023487	1	103	
SPRING-RETURN RIGHT	023488	1	103	
SWITCH A.-DRAW-TWIN TWIST	X39269	1	103	
BRACKET-DRAW SWITCH-TWIN TWIST	039264	1	103	
SWITCH-LEVER-SPDT-11A-125-277V	039252	2	103	
SWITCH A.-PRESSURE	X32660	2	103	
ACTUATOR-LEAF TYPE	032653	2	000	
BODY-PRESSURE SWITCH	032633	2	103	
CAP-SWITCH-PRESSURE	032635	2	103	
DIAPHRAGM-PRESSURE SWITCH	020249	2	103	
O-RING-1/2ID X 5/8 OD	017998	2	000	
PISTON-PRESSURE SWITCH	032634	2	103	
SPRING-COMP.480X.047X1.00	032651	2	103	
SWITCH-PLUNGER-SPDT15A125-25	032260	2	103	
SWITCH-LEVER-SPDT-11A-125-277V	039252	2	103	
SWITCH-PLUNGER-SPDT15A125-250V	032260	2	103	
SWITCH-PRESSURE 440 PSI-SOLDER	048230	2	103	
SWITCH-TOGGLE-DPDT*ON-NONE-ON	037394	1	103	POWER
TANK A.-MIX W/DECALS	X38755	2	103	
DECAL-MIX TANK-WRONG SIDE OUT	038750	2	000	
TANK-MIX 9-GALLON TAPERED BOTTOM	034928	2	103	
TOOL-LIQ.VALVE BODY EXTRACTING	035793	1	000	
TRANS.-240V PR1/24V SEC 10 VA	030132-27	1	103	
TRANS.-CONT.-ANTICIPATOR 20	016352-27	2	103	LOW VOLTAGE CONTROL PUMP
TRAY-DRIP 22-7/8L X 5-1/8W	014533	1	103	

+ Available Separately

DESCRIPTION	PART NUMBER	QTY.	WARR. CLASS	REMARKS
TRIM A.-SHELF	X24813	1	103	BELOW DRIP TRAY
TRIM A.-SIDE	X22424	2	103	
TRIM-BOTTOM MIX DOOR	024826	1	103	
TRIM-FRONT LEFT	024824-SP	1	103	
TRIM-FRONT RIGHT	024825	1	103	
TRIM-REAR CORNER	022013	2	103	RIGHT & LEFT
TUBE A.-MIX INLET-SOFT SERVE	X23124	2	103	
+O-RING-13/16 OD X .103W	019330	2	000	
+SEAL-INLET TUBE	032886	2	000	
TUBE A.-SUCTION *18 INCH	X37293	2	103	
COUNTERWEIGHT-SUCTION TUBE	020452	2	103	
TUBE-VINYL 5/8 ID X 1/8 WALL	020945-18	2	000	
TUBE-VINYL 1/4 ID X 3/8 OD	R30312	7'	000	
TUBE-VINYL 3/16IDX5/16OD-100'R	R30314	3'	000	
VALVE A.-ACCESS - CABINET	X49653	1	103	
VALVE A.-DRAW	X18303	3	103	
VALVE-ACCESS 1/4 X 3/8 SOLDER	029406	1	103	
VALVE-ACCESS 1/4FL X 1/4SOLDER	044404	1	103	SUCTION LINE
VALVE-ACCESS 1/4FL X 3/8SOLDER	043232	2	103	
VALVE-ACCESS-1/4 MFLX1/4 S-90	047016	2	103	
VALVE-EPR 1/4S	022665	1	103	SUCTION LINE
VALVE-EXP-AUTO-1/4S X1/4 FPT	046365	2	103	
+BOOT-EXPANSION VALVE	050900	2	000	
WIRE A.-PRESSURE*LONG*	X32663	2	103	FOR X51985 PRESSURE SWITCH

+ Available Separately

